

GROVE AT180

18-METRIC TON
(20 U.S.-TON)
ALL TERRAIN

HYDRAULIC CRANE WITH
TRAPEZOIDAL BOOM



HYDRAULIC
CRANES

†Patented Grove feature



POWERED FOR THE HIGHWAY...

Here's the crane to get you to the job site quickly . . . with excellent over-the-road performance in both city and highway travel. Front and rear spring suspension, excellent weight distribution, and the comfort of a rubber-mounted cab provide a smooth, easy ride at highway speeds. Mechanical, power assisted front wheel steering provides easy maneuverability in heavy traffic.



EASY TRAVELLER OFF HIGHWAY!



Off-highway, the AT180 becomes a rugged, powerful traveller with four wheel drive and steer and ample axle oscillation to maintain tire-to-ground contact while negotiating uneven terrain. Off-highway travel is controlled from the crane operating cab where the operator has control over axle oscillation lockout, permitting pick and carry operations.

The AT180 is a rough terrain crane designed to meet conditions for highway operations . . . It's the crane for the man who wants to move in, get the job done, and move to the next job.

**D GREAT PLACE TO WORK...
A PLEASURE TO DRIVE**

- Dual station—one for roading and one for crane operation.
- Roading cab arranged for comfort and convenience.
- Crane station has full controls for both crane operation and off-highway travel.
- Load visibility is excellent.

**E HIGH STRENGTH,
LONG REACH BOOM**

Grove-patented Trapezoidal boom.

- 3-section, full power.
- 6.7m (22') "Swingaway" boom extension for a maximum tip height of 29m (95').
- 0 to 75° elevation.
- Grove hoist Model 15H-16A.

designed
members
base.
maximum
gral with
se.
ggers for
t.

designed
members
base.
maximum
gral with
se.
ggers for
t.

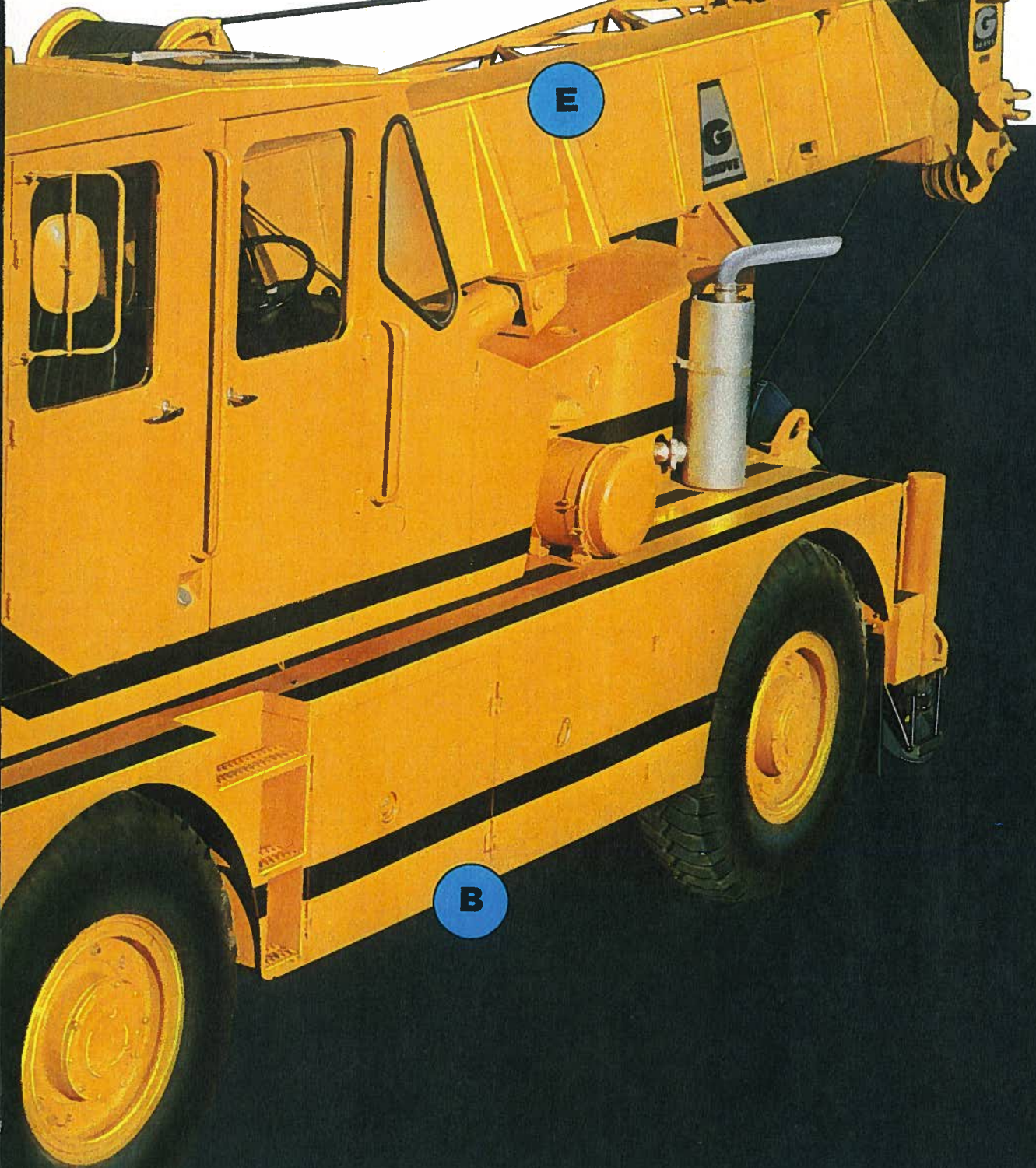

D

E

E

B



SPECIFICATIONS

BOOM—8.8m–28.0m (29'–92'), 4-section boom; 2 full power trapezoidal sections to 21.3m (70') with integral check valves on each telescoping cylinder and a 6.7m (22') "Swingaway" lattice boom extension. Boom telescope sections are individually controlled. Each boom section is supported on graphite impregnated nylatron wear pads.

BOOM NOSE—Four sheaves with 349mm (13.75") root dia. giving a 22:1 dia. ratio with 16mm (5/8") rope, mounted on heavy duty tapered roller bearings. Removable pin type rope guards allow easy reeving. Rope dead ends on either side of the boom nose.

BOOM ELEVATION—Dual double-acting hydraulic cylinders with integral holding valves; elevation from 0° to 75°. Control lever and foot pedal provided for hand or foot operation.

SWING—Ball bearing swing circle, 360° continuous rotation. "Grove Planetary Swing" with automatic disc swing brake, hand operated 360° position positive turntable lock. Swing speed 3.14 RPM.

CAB—Located on left side of turntable on vibration and sound isolating rubber mounts, dual station—one for roading and one for crane operation; fully enclosed, laminated safety glass windows throughout; hinged skylight over crane operator's station; fully adjustable operator's seats. Windshield wipers for front and rear windows and skylight, with washer for driver's windshield; cab-mounted work lights, dual rear view mirrors, electric swing & highway horn, diesel heater, defroster, domelights, dashlights, door locks.

CAB INSTRUMENTATION & CONTROLS—Engine oil pressure gauge, engine water temperature gauge, voltmeter, electric fuel gauge, electric tachometer, dual air pressure gauge, transmission and torque converter oil temperature gauge, electric boom angle indicator, sight leveling bubble, combination hand and foot throttle, all crane functions and outrigger controls.

OUTRIGGERS—Double box, integral with main frame; hydraulic, telescoping beams & vertical jacks with integral check valves. Beams extend to 5.5m (18') centerline-to-centerline, retract to 2.4m (8'). Independent or simultaneous control in-out-up-and-down. Sequence control arrangement eliminates accidental actuation. Self-storing 381mm (15") dia. steel floats. Outrigger controls located in operator cab.

MAIN FRAME—Hi-strength steel, parallel box type construction with boxed crossmembers, reinforced to insure a rigid turntable mounting. Front and rear lifting and tie-down lugs are integral with the main frame.

TORQUE CONVERTER—Engine mounted, with pump drive, pump disconnect, and converter lockup.

TRANSMISSION—6 speeds forward and reverse, power shift with rear axle disconnect.

AXLES—Front and rear—Drive steer axle, planetary reduction with drop gear. Overall ratio 9.145:1. Rear axle equipped with no-spin differential.

SUSPENSION—Front and rear—Spring suspension with hydraulic cylinder axle lockouts with shock absorbing ability.

HOIST SPECIFICATIONS

Description: Power up and down, equal speed, planetary reduction with integral automatic brake and hoist drum rotation indicator.

HOIST DATA	MAIN HOIST Grove Model 15H-16A
Drum Dimensions	305mm dia. (12 in.) 406mm length (16 in.) 445mm dia. flange (17.5 in.)
Performance: Max. Single Line Speed Max. Single Line Pull	107.3m/min (352 FPM) 4157kg (9,165 lb.)
Drum Rope Storage Capacity	**146.3m of 16mm dia. rope (480 ft. of 5/8 in.)
Permissible Single Line Rope Pull	16mm (5/8 in.) 6x37 class— 3595kg (7,926 lb.) 16mm (5/8 in.) 19x7 class— 3595kg (7,926 lb.)

***6th layer of rope not recommended for hoisting operations*

BRAKES—Service—Air over hydraulic on all 4 wheels. Brake size 432mm x 102mm (17" x 4"), total lining area 3905cm² (605.2''²).
Parking—Spring actuated, air released, 356mm (14") disc brakes on drive shaft.

TIRES—14.00 x 24-20PR hiway front and rear.

STEERING—Mechanical steering with power boost on front axle for roading; mechanical steering link manually disconnected for crane operation. Four wheel, full power steering for crane operation.

HYDRAULIC SYSTEM:

RESERVOIR—378.5 liter (100 gal.) capacity, clean-out access and exterior oil level sight.

FILTER—Full flow return line replaceable 25 micron cartridge with by-pass protection and filter by-pass indicator.

PUMPS—3 main gear pumps driven from torque converter. Pump disconnect for roading.

CAPACITIES at 2400 RPM (pump speed)

Pump 1—176 LPM (46.5 GPM)

2—149.5 LPM (39.5 GPM)

3—100.3 LPM (26.5 GPM)

Single stage steer pump—68 LPM (18 GPM)

CONTROL VALVES—4 way, 3 position, spring centered directional control valves with integral main and circuit relief valves. Simultaneous multiple crane functions are possible through the use of 3 banks of valves.

OIL COOLER—Full flow, fin & tube, oil to air.

POWER DISTRIBUTION—(Main hoist boost, lift, mid telescope, rear steer: maximum system pressure—176kg/cm²(2500/psi))(main hoist: maximum system pressure—158kg/cm²(2250psi)) (fly telescope, swing, outriggers, lockout cylinders: maximum system pressure—158kg/cm²(2250psi)).

AT180

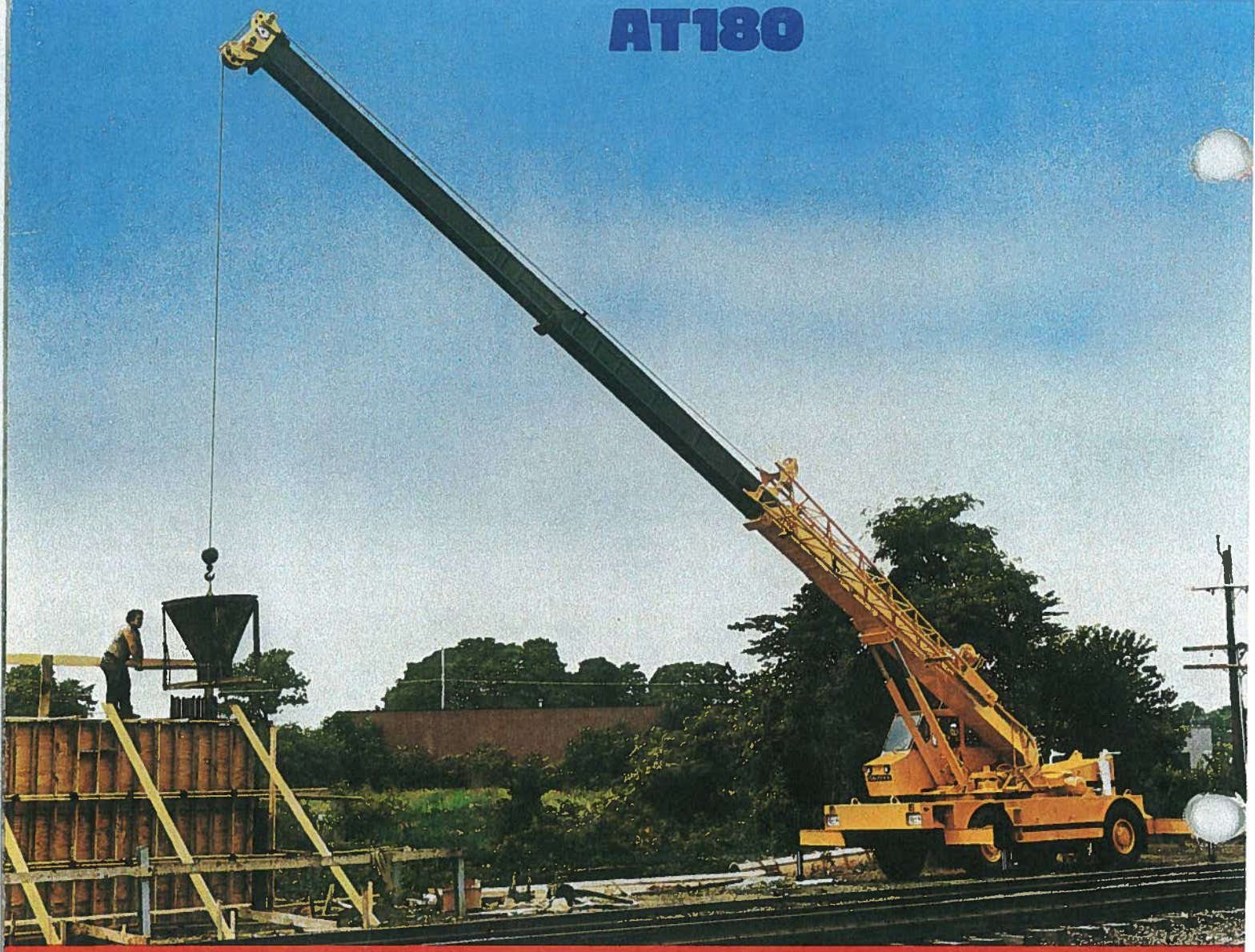

**THE MOST COMPLETE LINE OF
HYDRAULIC CRANES FOR
CONSTRUCTION & INDUSTRY**

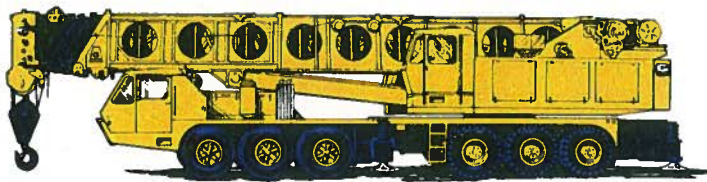

CARRIER MOUNTED CRANES
13.4 through 113.5 tons metric
(15 through 125 U.S. tons)



**ROUGH
TERRAIN
CRANES**
7.3 through 45 tons metric
(8 through 50 U.S. tons)



**INDUSTRIAL
CRANES**
1.8 through 31.8 tons metric
(2 through 35 U.S. tons)



HYDRAULIC CRANES

GROVE MANUFACTURING CO.
Division of Walter Kidde & Company, Inc.
SHADY GROVE, PA. 17256 U.S.A.

ENGINE SPECIFICATIONS

MAKE & MODEL	Cummins Diesel V8-210	*Caterpillar Diesel 3208
TYPE	8 Cylinder OHV	8 Cylinder OHV
BORE & STROKE	117mm x 95mm (4.625" x 3.75")	114mm x 130mm (4.5" x 5.0")
DISPLACEMENT	8259cm ³ (504 cu.in.)	10 422cm ³ (636 cu.in.)
HORSEPOWER (NET)	175 @ 2800 RPM	157 @ 2800 RPM
GOVERNED RPM	2800 RPM	2800 RPM
TORQUE (NET)	50kgm @ 1900 RPM (365 lb.ft.)	50kgm @ 1800 RPM (360 lb.ft.)
ELECTRICAL SYSTEM	12-volt, Negative Ground	12-volt, Negative Ground
COMBUSTION SYSTEM	4 Cycle, Naturally Aspirated	4 Cycle, Naturally Aspirated
COOLING SYSTEM	Liquid	Liquid
FUEL CAPACITY	227 liters (60 gal.)	227 liters (60 gal.)
ALTERNATOR	90 Amp., 12-volt	90 Amp., 12-volt
BATTERY	(2) 204 A.H., 12-volt	(2) 204 A.H., 12-volt
AIR CLEANER	Dry Type	Dry Type
AIR COMPRESSOR	374 LPM (13.2 ft. ³ /min)	340 LPM (12 ft. ³ /min)
HOURLY METER	Yes	Yes

* Denotes optional equipment

SPEED AND GRADEABILITY

Forward Drive	Transmission Range	Gear Shift	Maximum Speed		Gradeability @ Stall %	Tractive Effort At Stall	
			KM/H	MPH		KG	LB.
4 Wheel Drive	Low	1st	5	3.2	99	14 455	31 868
4 Wheel Drive	Low	2nd	11	6.6	34.2	6863	15 131
4 Wheel Drive	Low	3rd	28	17.7	10.7	2517	5548
2 Wheel Drive	High	1st	14	9.0	23.8	5023	11 073
2 Wheel Drive	High	2nd	30	18.6	10.0	2381	5250
2 Wheel Drive	High	3rd	72	45.0	2.4	873	1925

NOTE: All performance data is based on standard machine and may vary plus or minus 10% due to variations in engine performance and vehicle weight. Max. speed is limited to 72 km/h (45 MPH)

DIMENSIONS

IN MILLIMETERS

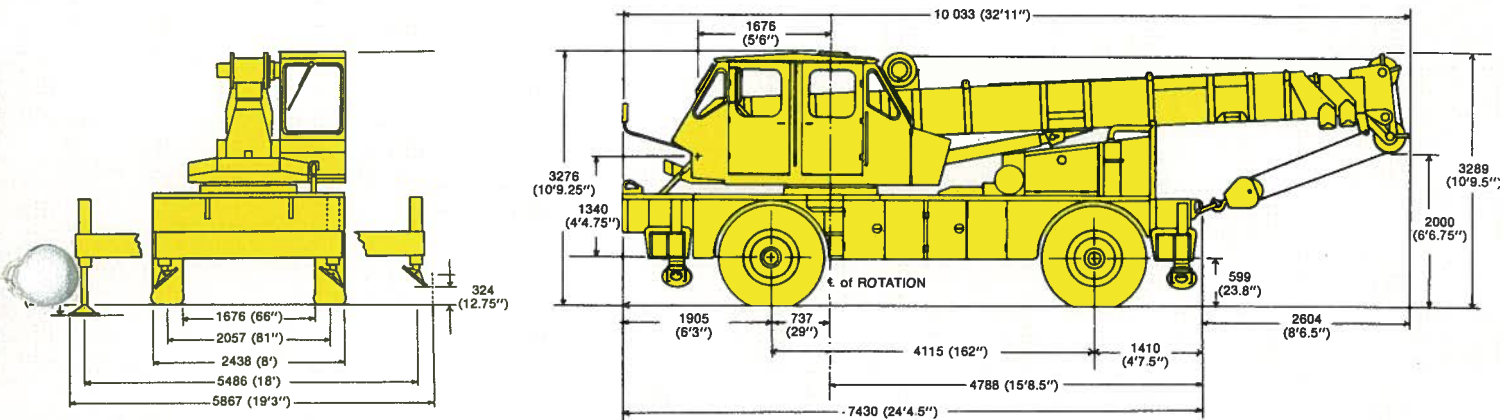

OUTSTANDING MANEUVERABILITY

The AT180 is at home in city traffic, the open road or on rough terrain. It is the narrowest and shortest crane in its class and offers 2-wheel steering for highway travel and 4-wheel steering for off-highway. Four-wheel steering provides the close-quarter maneuvering necessary for much of the pick and carry work at the job site.

TWO WHEEL STEER

Turning radius 11.0m (36')
Clearance radius 11.9m (39')

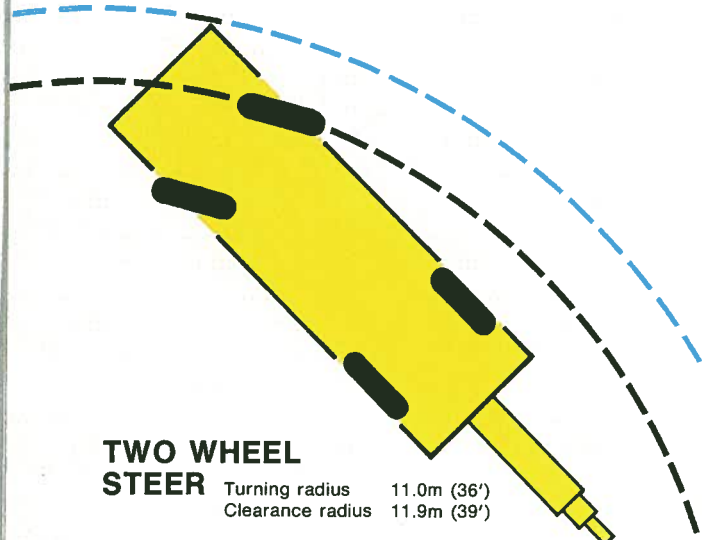

FOUR WHEEL STEER

Turning radius 6.0m (19'8")
Clearance radius 7.8m (25'7")

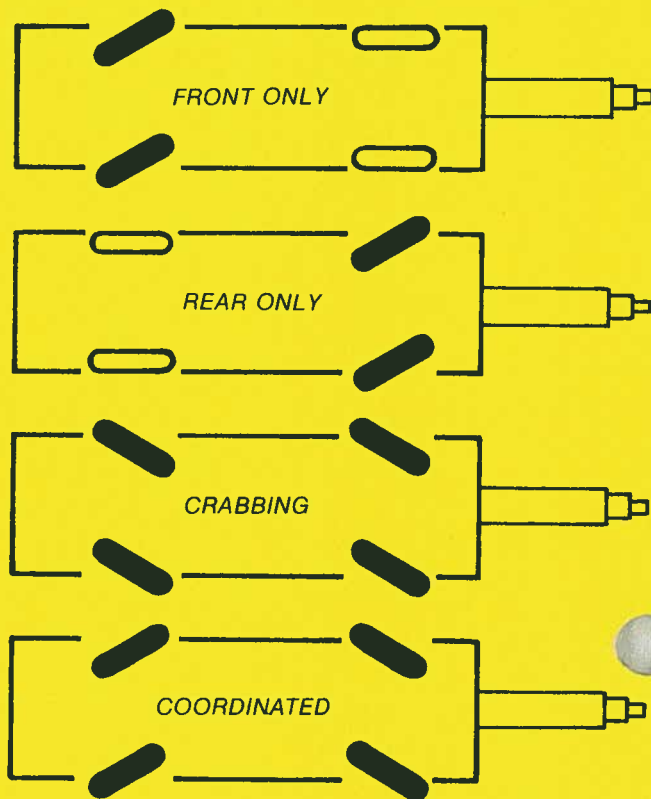
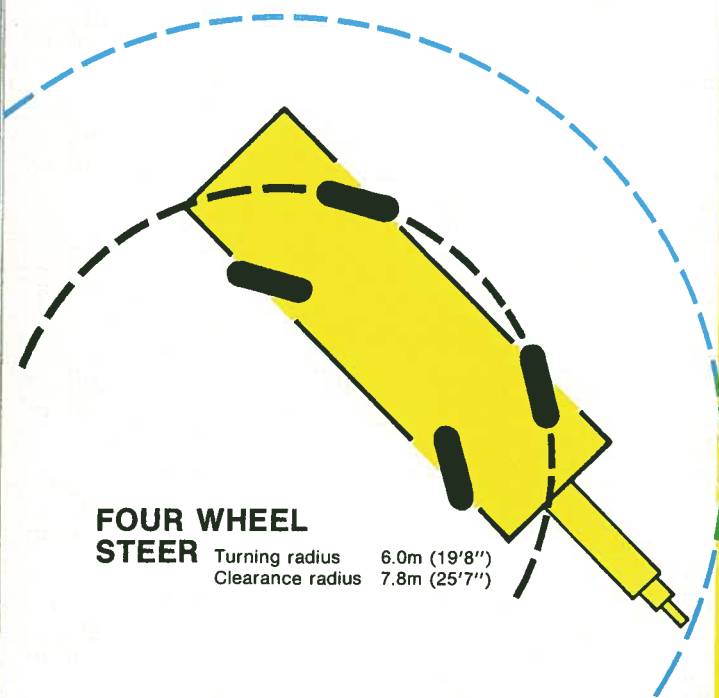

THE GROVE TRAPEZOIDAL[†] BOOM

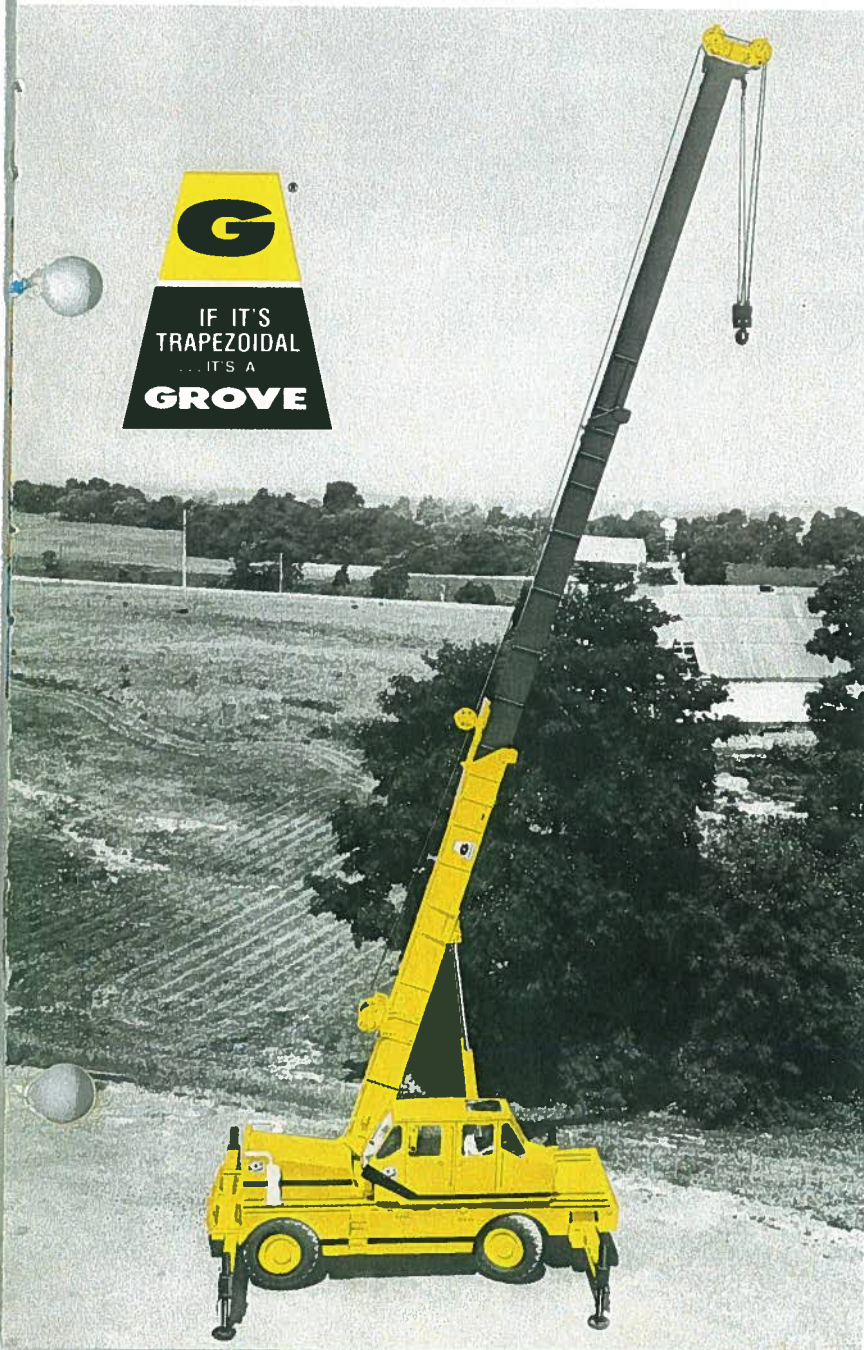

THE BOOM WITH THE OPTIMUM STRENGTH-TO-WEIGHT RATIO FOR HYDRAULIC CRANE OPERATION.

The Grove Trapezoidal Boom design combined with the use of high strength steels results in a boom that is stronger with more rigidity and greater resistance to both vertical and horizontal deflection. This gives you more lifting capacity without an increase in boom weight . . . and, most important, greater long boom capacity.

In the development of the trapezoidal boom, Grove engineers discovered that when a conventional rectangular boom and a trapezoidal boom are designed to the same lifting capacity, the trapezoidal boom is the lighter of the two. When the two booms are designed to equal weight, the trapezoidal boom is of course stronger, more rigid and provides greater lifting capacity. For a crane like the AT180, where Gross Vehicle Weight is an important consideration, the trapezoidal boom provides the combination of light weight and outstanding capacity. You'll find this especially true on lifts requiring maximum extension.

DUAL-POSITION CAB, TURNTABLE-MOUNTED...

*Designed for
operator comfort
and convenience*

- ① MECHANICAL STEERING
WITH POWER ASSIST
- ② 4-WHEEL HYDRAULIC
STEERING
- ③ RUBBER MOUNTED,
ACOUSTICALLY TREATED
- ④ FULLY ADJUSTABLE
SEAT
- ⑤ FULLY INSTRUMENTED
CONTROL PANELS
- ⑥ STANDARDIZED CRANE
CONTROLS, EASILY
AT-HAND
- ⑦ HINGED SKYLIGHT
WITH WIPER
- ⑧ OUTRIGGER CONTROLS
- ⑨ ELECTRONIC BOOM
ANGLE INDICATOR

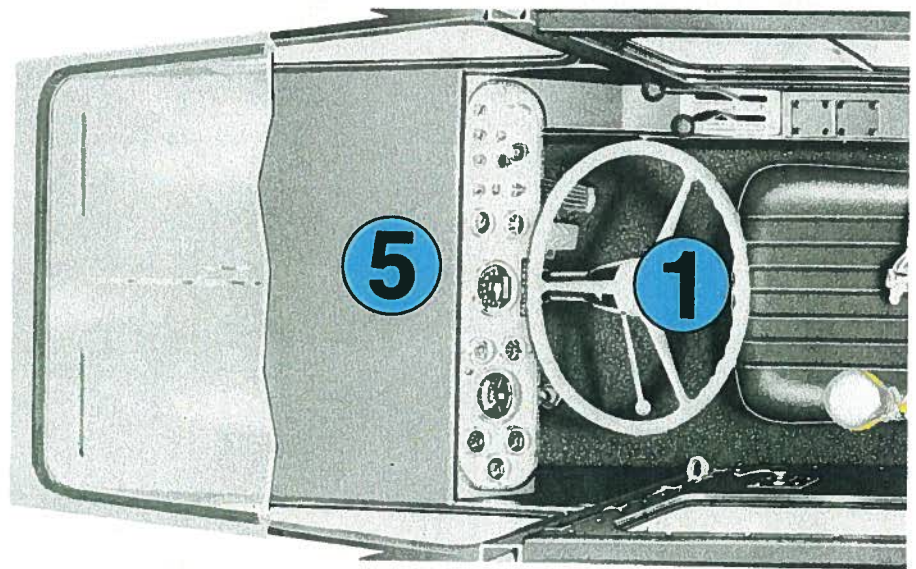

ROADING CAB

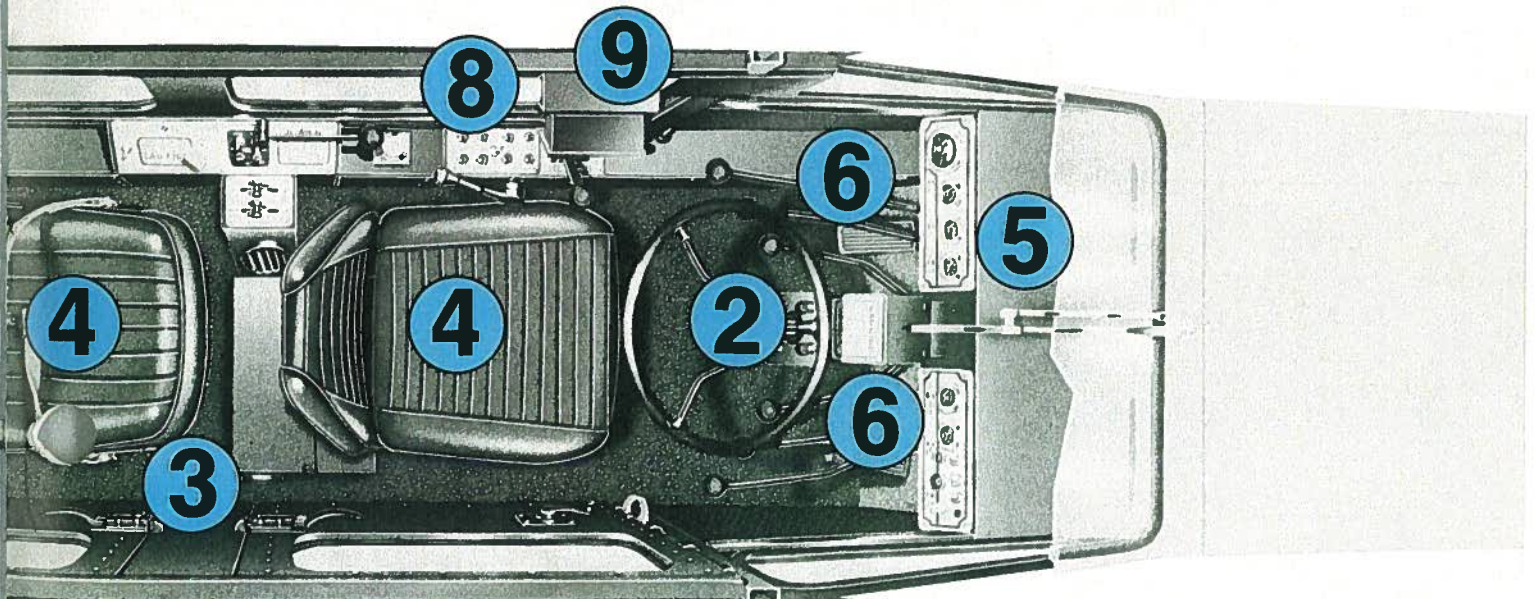
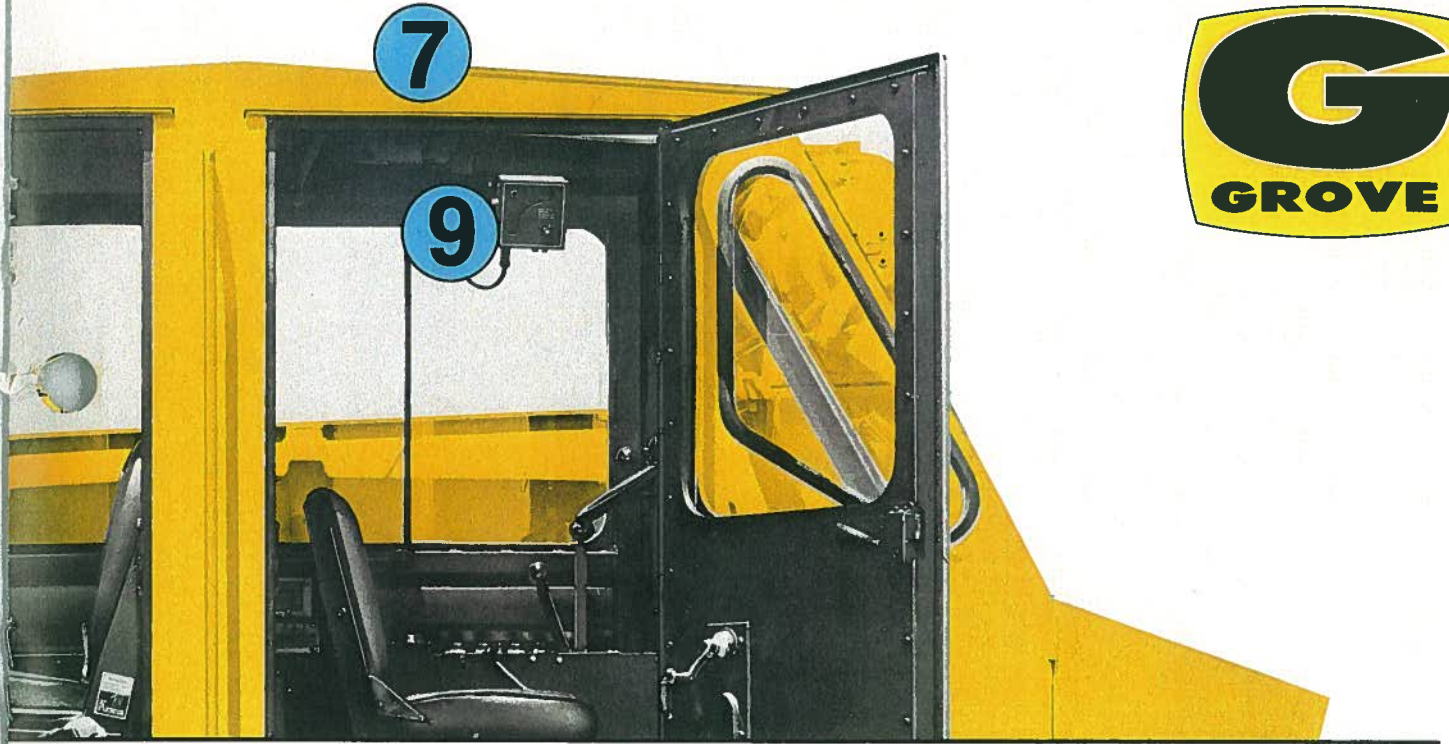

CRANING CAB

HIGH STRENGTH ROUGH RIGID

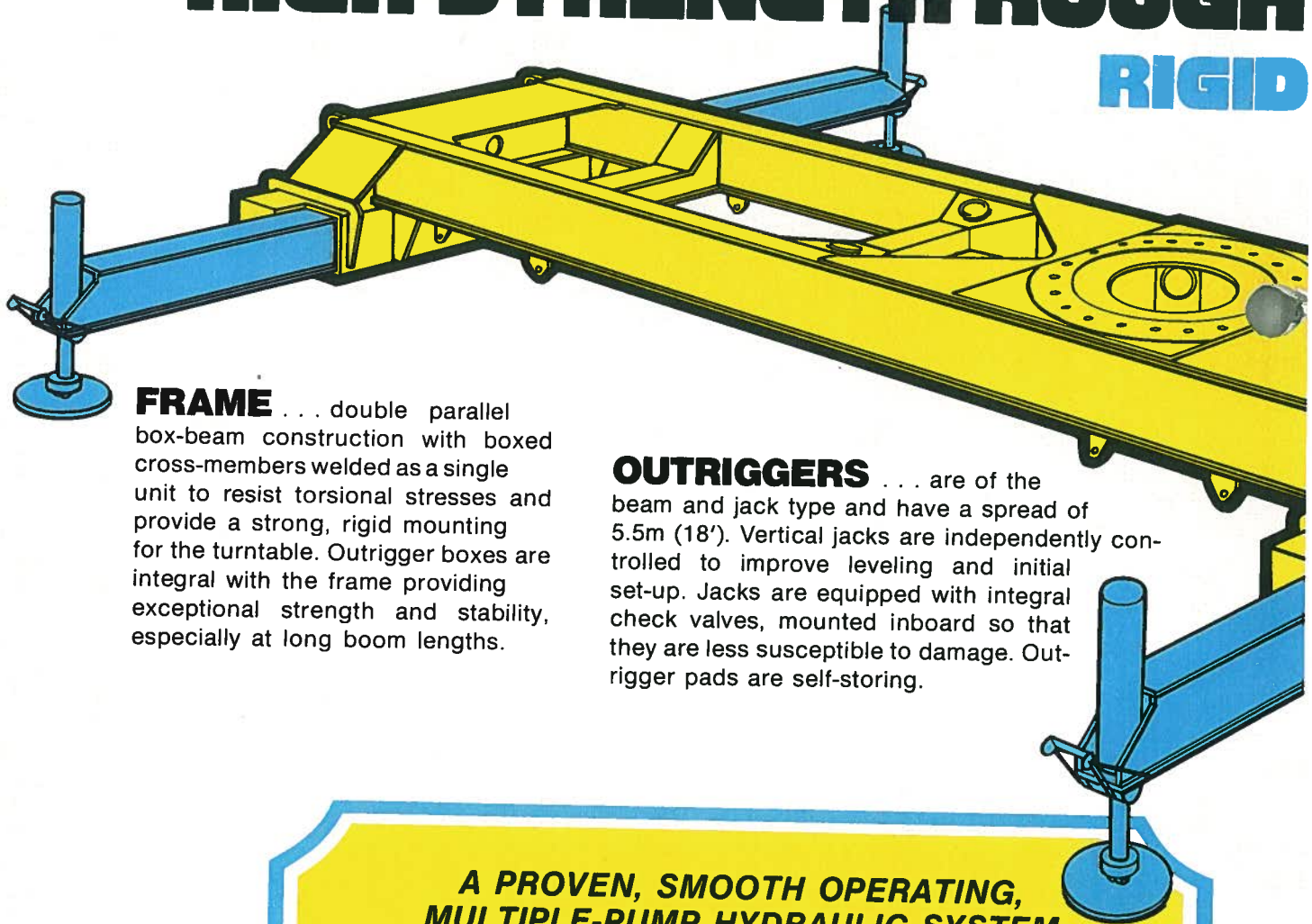

FRAME . . . double parallel box-beam construction with boxed cross-members welded as a single unit to resist torsional stresses and provide a strong, rigid mounting for the turntable. Outrigger boxes are integral with the frame providing exceptional strength and stability, especially at long boom lengths.

OUTRIGGERS . . . are of the beam and jack type and have a spread of 5.5m (18'). Vertical jacks are independently controlled to improve leveling and initial set-up. Jacks are equipped with integral check valves, mounted inboard so that they are less susceptible to damage. Out- rigger pads are self-storing.

A PROVEN, SMOOTH OPERATING, MULTIPLE-PUMP HYDRAULIC SYSTEM

The AT180 is equipped with a multiple-pump hydraulic system with precision four-way double-acting, fully featherable control valves which permit precise operation under load. Simultaneous multiple crane functions are possible through the use of three banks of control valves.

TERRAIN CHASSIS

LIFTING BASE

AIR-OVER-HYDRAULIC BRAKE SYSTEM

The AT180 has a dual air-over-hydraulic four-wheel service brake system. The hydraulic and air systems are divided, one to each axle, with a pressure protection valve favoring the rear axle.

In addition, a mechanical disc type parking brake is mounted on the drive shaft. It is spring applied and air released.

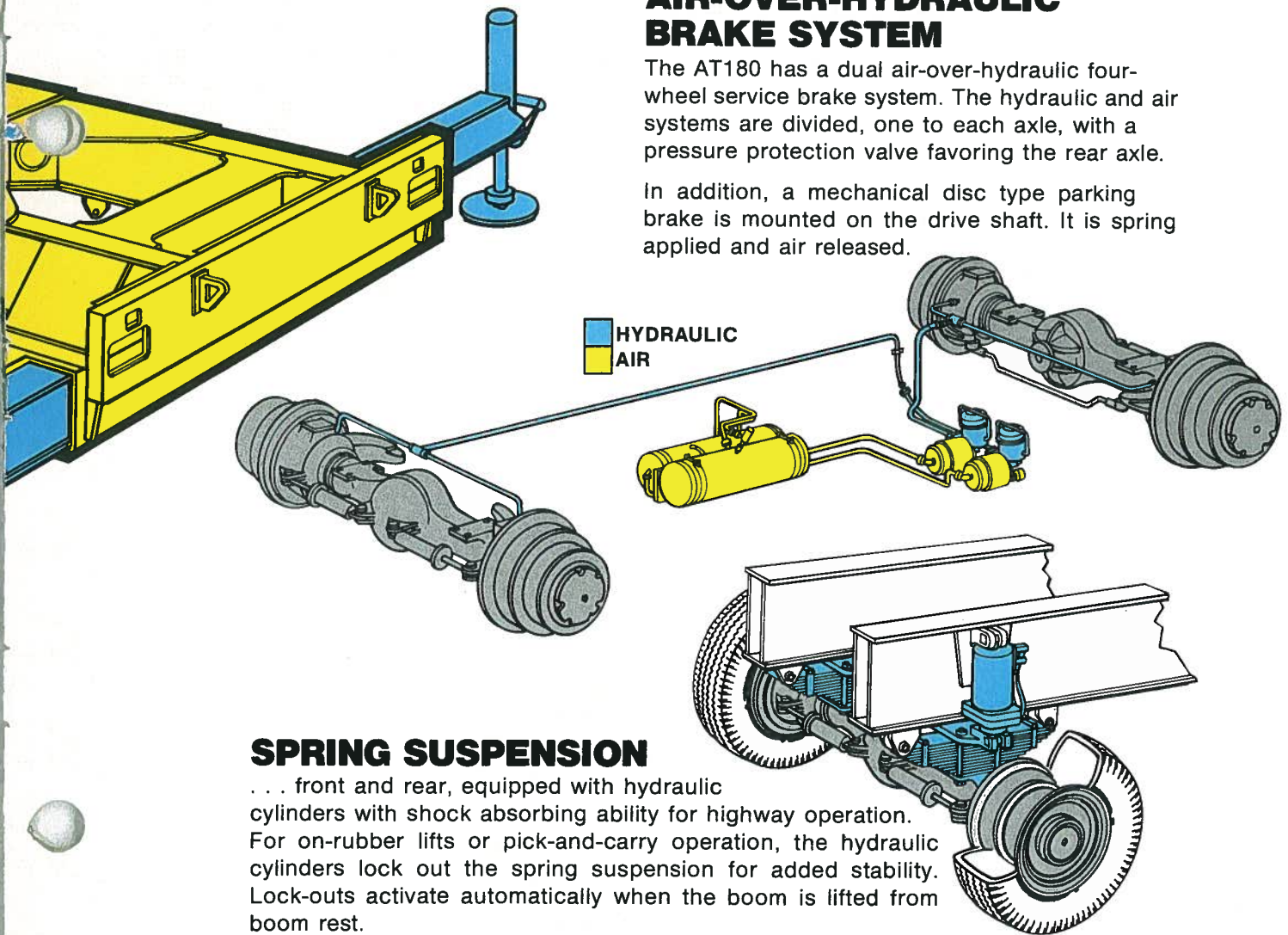

SPRING SUSPENSION

. . . front and rear, equipped with hydraulic cylinders with shock absorbing ability for highway operation. For on-rubber lifts or pick-and-carry operation, the hydraulic cylinders lock out the spring suspension for added stability. Lock-outs activate automatically when the boom is lifted from boom rest.



PICK AND CARRY CAPABILITY

Good balance is inherent in the AT180. It can be used for transporting equipment and components around the job site. Operator has full view of the load and the advantage of four steering modes for maximum maneuverability.

AXLE WEIGHT DISTRIBUTION CHART

ITEM	KILOGRAMS			POUNDS		
	GROSS	FRONT	REAR	GROSS	FRONT	REAR
1. Basic Unit consists of: 8.8–21.3m (29–70') trapezoidal boom, 6.7m (22') Swingaway extension, Grove 15H-16A main hoist with 106.7m (350') of 16mm (5/8") diameter rope, 431kg (950 lb.) counterweight, Cummins V8-210 diesel eng.	19 388	9941	9 447	42,742	21,916	20,826
2. ADD: 22.7mt (25 ton) Hookblock-3 sheave (over rear)	+ 234	- 103	+ 337	+ 516	- 226	+ 742
22.7mt (25 ton) Hookblock-4 sheave (over rear)	+ 255	- 112	+ 367	+ 561	- 246	+ 807
•• Spare tire w/carrier	+ 20	+ 81	- 61	+ 45	+ 179	- 134
•• Kruger LMI & Anti-two block system w/control lever lockout	- 47	- 196	+ 149	- 104	- 433	+ 329
Hoist drum cable follower	+ 27	+ 18	+ 9	+ 60	+ 39	+ 21
3. Substitute: 3 sheave boom nose	- 23	+ 22	- 45	- 50	+ 49	- 99
CAT 3208 diesel engine	- 102	+ 16	+ 86	+ 225	+ 36	+ 189
4. Remove: 6.7m (22') Swingaway boom extension	- 502	+ 39	- 541	- 1,106	+ 86	- 1,192
106.7m (350') of 16mm (5/8") wire rope	- 114	- 69	- 45	- 252	- 151	- 101
• Standard 431kg (950 lb.) counterweight	- 431	- 549	+ 118	- 950	- 1,210	+ 260

NOTE: Weight distribution figures for Kruger LMI and spare tire options include allowance for counterweight adjustments.

- NOTE:
- 431kg (950 lb.) counterweight used without Kruger LMI system and spare tire.
 - 215kg (475 lb.) counterweight used when unit equipped with either Kruger LMI system or spare tire.
 - No counterweight used when unit equipped with both Kruger LMI system and spare tire.

GROVE®

FULL HYDRAULIC SELF-PROPELLED CRANE

AT180

20 TON CAP.

PCSA CLASS 10-69

RATED LIFTING CAPACITIES IN POUNDS 29 ft. - 92 ft. BOOM

ON OUTRIGGERS FULLY EXTENDED - 360°

Radius in Feet	Boom Length in Feet								70 ft. + 22 ft. Ext. *92
	29	34	40	46	52	58	64	70	
10	40,000 (58.5)	38,000 (64)	36,200 (68.5)	31,200 (72)	28,000 (74.5)				
12	36,400 (54)	36,400 (60)	34,000 (65)	29,100 (69.5)	26,000 (72.5)	23,900 (74.5)			
15	29,300 (46)	29,300 (54)	29,300 (60.5)	26,400 (65.5)	23,500 (68.5)	21,500 (71.5)	21,000 (74)	21,000 (75)	
20	20,700 (29.5)	20,700 (42.5)	20,700 (52)	20,700 (58)	20,200 (62.5)	18,400 (66)	17,400 (69)	17,000 (71.5)	11,000 (75)
25		14,440 (27)	14,440 (42)	14,440 (50)	14,440 (56)	14,440 (60.5)	14,440 (64)	14,300 (67)	9,300 (73.5)
30			10,580 (29)	10,580 (41)	10,580 (49)	10,580 (54.5)	10,580 (58.5)	10,580 (62.5)	7,800 (70)
35				8,290 (30)	8,290 (41)	8,290 (48)	8,290 (53)	8,290 (57.5)	6,750 (66.5)
40					6,890 (31.5)	6,890 (40.5)	6,890 (47)	6,890 (52)	5,900 (62.5)
45						5,520 (31.5)	5,520 (40)	5,520 (46.5)	5,520 (58.5)
50						4,380 (19)	4,380 (32)	4,380 (40)	4,700 (54.5)
55							3,480 (21.5)	3,480 (33)	3,910 (50.5)
60								2,680 (23)	3,180 (46)
65									2,590 (41)
70									2,070 (36)
75									1,630 (29.5)
80									1,210 (22)

A6-829-002527 & -002533

NOTE: Boom Angle (degrees) in reference for given lift appears below the load.

ON OUTRIGGERS FULLY EXTENDED - OVER REAR

Radius in Feet	Boom Length in Feet								70 ft. + 22 ft. Ext. *92
	29	34	40	46	52	58	64	70	
10	40,000 (58.5)	38,000 (64)	36,200 (68.5)	31,200 (72)	28,000 (74.5)				
12	36,400 (54)	36,400 (60)	34,000 (65)	29,100 (69.5)	26,000 (72.5)	23,900 (74.5)			
15	29,300 (46)	29,300 (54)	29,300 (60.5)	26,400 (65.5)	23,500 (68.5)	21,500 (71.5)	21,000 (74)	21,000 (75)	
20	20,700 (29.5)	20,700 (42.5)	20,700 (52)	20,700 (58)	20,200 (62.5)	18,400 (66)	17,400 (69)	17,000 (71.5)	11,000 (75)
25		15,400 (27)	15,400 (42)	15,400 (50)	15,400 (56)	15,400 (60.5)	15,100 (64)	14,300 (67)	9,300 (73.5)
30				12,300 (29)	12,300 (41)	12,300 (49)	12,300 (54.5)	12,300 (58.5)	7,800 (70)
35					10,000 (30)	10,000 (41)	10,000 (48)	10,000 (53)	6,750 (66.5)
40						8,300 (31.5)	8,300 (40.5)	8,300 (47)	5,900 (62.5)
45							6,950 (31.5)	6,950 (40)	5,250 (58.5)
50							5,850 (19)	5,850 (32)	4,700 (54.5)
55								4,950 (21.5)	4,200 (50.5)
60									3,850 (46)
65									3,500 (41)
70									3,100 (36)
75									2,750 (29.5)
80									2,500 (22)

A6-829-002524 & -002533

NOTE: Boom Angle (degrees) in reference for given lift appears below the load.

Capacities appearing above bold line are based on structural strength and tipping should not be relied upon as a capacity limitation. Capacities do not exceed 85% of tipping loads as determined by test in accordance with SAE J-765. No loads to be lifted with main boom below 10° boom angle. *Boom must be fully extended when lifting with 22 ft. boom extension.

ON RUBBER CAPACITIES

Radius in Feet	Stationary Capacity	Stationary Capacity	2.5 MPH	Stationary Capacity
	Boom Centered Over Rear	Defined Arc (1) Over Rear	Boom Centered (8) Over Rear	360° Arc
10	40,000 (a)	33,800 (a)		11,480 (d)
12	36,400 (b)	30,000 (b)		8,890 (e)
15	29,300 (c)	25,320 (c)	18,650 (a)	6,490 (e)
20	20,700 (c)	18,800 (c)	13,300 (a)	3,670 (f)
25	15,400 (d)	14,800 (d)	9,660 (b)	1,860 (f)
30	11,660 (d)	11,660 (d)	7,570 (c)	950 (f)
35	8,780 (f)	8,780 (f)	6,220 (d)	
40	6,760	6,760	5,090 (e)	
45	5,320	5,320	4,180 (f)	
50	4,220	4,220	3,410 (f)	
55	3,290	3,290	2,640 (g)	
60	2,500	2,500	1,830	

A6-829-002535

Notes to On Rubber Capacities

- Defined Arc - Left rear track centerline to right rear track centerline.
- Capacities appearing above bold line are based on structural strength and tipping should not be relied upon as a capacity limitation.
- All lifting depends on proper tire inflation, capacity and condition. Rated loads are based on 14.00x24 (20 ply) bias tires and 110 PSI cold inflation pressure. Loads must be reduced for lower inflation pressures.
- Capacities not applicable to machines equipped with Michelin 14.00x24 XV or any radial tires.
- Capacities are applicable with the machine on a firm level surface only.
- 22 ft. boom extension not permitted for on rubber lifts.
- No loads to be lifted with main boom below 10° boom angle.
- For 2.5 MPH pick and carry operation, boom must be centered over rear of machine and mechanical swing lock engaged. (Engaging mechanical swing lock with boom centered over rear, automatically overrides the front axle lockouts.)
- Axle lockouts must be engaged before lifting on rubber. (Check automatic lockout system for proper functioning; refer to "Operation and Maintenance Manual" for description of a proper functioning axle lockout system).

Maximum Permissible Boom Length:

- 29 ft.
- 34 ft.
- 40 ft.
- 46 ft.
- 52 ft.
- 58 ft.
- 64 ft.

RANGE DIAGRAM

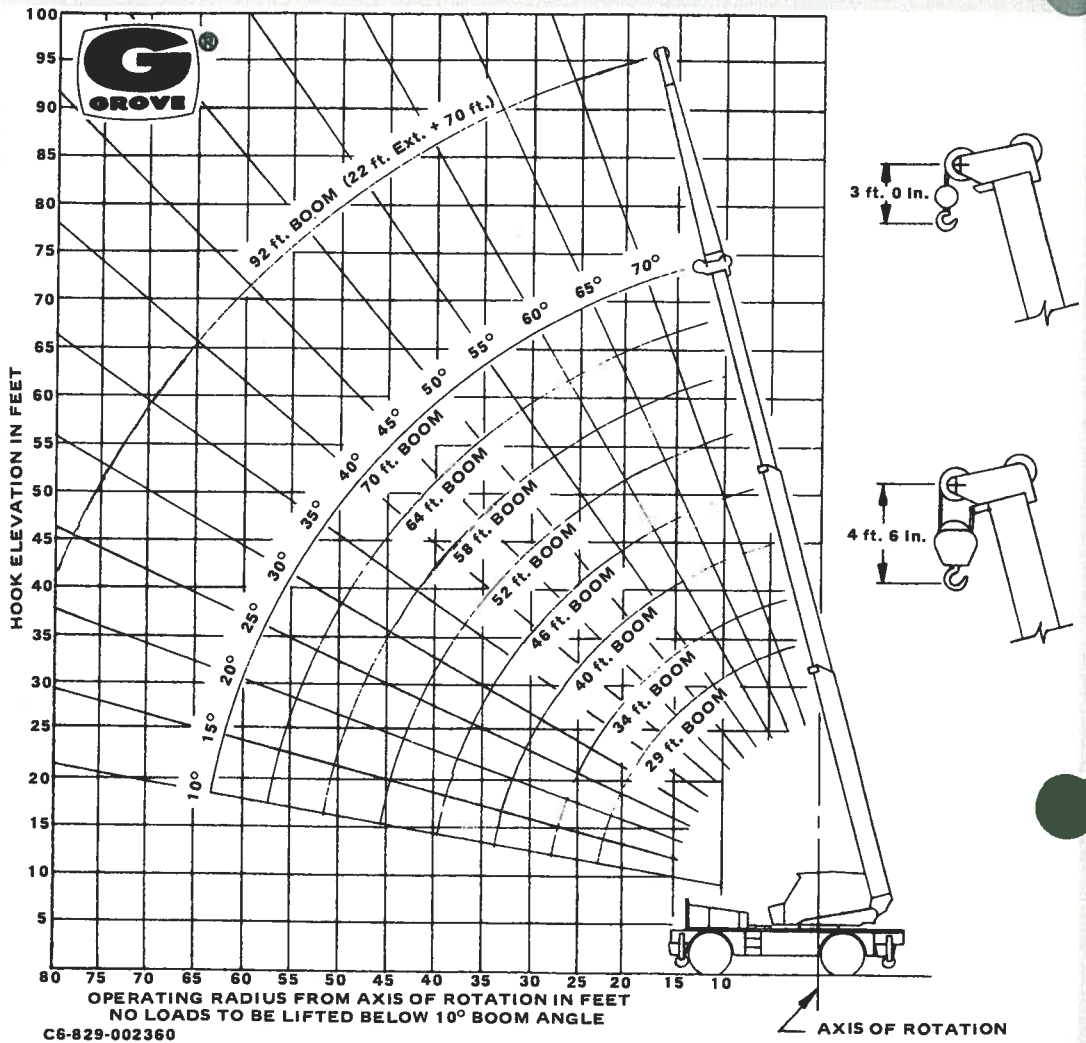

WEIGHT REDUCTIONS FOR LOAD HANDLING DEVICES

†22 ft. BOOM EXT. WITH 29-70 ft. BOOM	
Stowed	: 450 lbs.
Erected	: 2,200 lbs.

HOOK BLOCKS

25 Ton, 3 Sheave	: 550 lbs.
5 Ton, Headache Ball	: 150 lbs.
7½ Ton, Headache Ball	: 300 lbs.

NOTE: All load handling devices and boom attachments are considered part of the load and suitable allowances MUST BE MADE for their combined weights. Weights are for Grove furnished equipment.

†Reduction of main boom lifting capacities.

NOTES TO LIFTING CAPACITIES

- Do not exceed any rated lifting capacity. Rated lifting capacities are based on freely suspended loads with the machine leveled and standing on a firm supporting surface. Ratings with outriggers are based on outriggers being extended to their maximum position and tires raised free of crane weight before extending the boom or lifting loads.
- Practical working loads for each particular job shall be established by the user depending on operating condition to include: the supporting surface, wind and other factors affecting stability, hazardous surroundings, experience of personnel, handling of load, etc. No attempt must be made to move a load horizontally on the ground in any direction.
- Operating radius is the horizontal distance from the axis of rotation before loading to the centerline of the vertical hoist line or tackle with loads applied.
- "On Rubber" lifting (if permitted) depends on proper tire inflation, capacity and condition. "On Rubber" loads may be transported at a maximum vehicle speed of 2.5 mi/hr (4 Km/hr) on a firm and level surface under conditions specified.
- Jibs may be used for lifting crane service only. Jib capacities are based on structural strength of jib or main boom and on main boom angle.
- Operation is not intended or approved for any conditions outside of those shown hereon. Handling of personnel from the boom is not authorized except with equipment furnished and installed by Grove Manufacturing Company.
- For clamshell or concrete bucket operation, weight of bucket and load must not exceed 80% of rated lifting capacities.
- Power-telescoping boom sections must be extended equally at all times. Long cantilever booms can create a tipping condition when in extended and lowered position.
- The maximum load which may be telescoped is limited by hydraulic pressure, boom angle, boom lubrication, etc. It is safe to attempt to telescope any load within the limits of rated lifting capacity chart.
- With certain boom and hoist tackle combinations, maximum capacities may not be obtainable with standard cable lengths.
- With certain boom and load combinations, raising of load with boom lift cylinders may not be possible. Operational safety is not affected by this condition.
- Keep load handling devices a minimum of 12 inches (30 cm) below boom head when lowering or extending boom.
- If actual boom length and/or radius is between values listed, use lifting capacity for the next longer rated length and/or radius.
- All load handling devices and boom attachments are considered part of the load and suitable allowances must be made for their combined weights.
- Operation of this equipment in excess of rating charts or disregard of the instructions is hazardous and voids the warranty and manufacturer's liability.



GROVE MANUFACTURING COMPANY

A DIVISION OF WALTER KIDDE & COMPANY, INC.

SHADY GROVE • PENNSYLVANIA 17256

MEMBER: POWER CRANE & SHOVEL ASSOCIATION

Form No. 1213476-10M

Printed in U.S.A.

Distributed by:

GROVE®

FULL HYDRAULIC CARRIER-MOUNTED CRANE

AT180

ON RUBBER CAPACITIES WITH 18.00 x 22.5 (18 PR) TIRES

RATED LIFTING CAPACITIES IN POUNDS
29 ft. - 70 ft. BOOM

Radius in Feet	Stationary Capacity	Stationary Capacity	2.5 MPH Capacity	Stationary Capacity
	Boom Centered Over Rear	Defined Arc (1) Over Rear	Boom Centered (7) Over Rear	360° Arc
10	21,750 (a)	18,270 (a)		3,796 (d)
12	19,520 (b)	15,910 (b)		2,518 (e)
15	15,370 (c)	13,050 (c)	9,610 (a)	1,258 (e)
20	10,400 (c)	9,150 (c)	6,480 (a)	
25	7,450 (d)	6,860 (d)	4,490 (b)	
30	5,410 (d)	5,130 (d)	3,330 (c)	
35	3,900 (f)	3,630 (f)	2,580 (d)	
40	2,790	2,530	1,900 (e)	
45	2,070	1,830	1,440 (f)	
50	1,520	1,300	1,060 (f)	
55	1,080	890		

Maximum Permissible Boom Length

- (a) 39 ft.
- (b) 34 ft.
- (c) 40 ft.
- (d) 46 ft.
- (e) 52 ft.
- (f) 58 ft.
- (g) 64 ft.

A6-829-003312

NOTES

- (1) Defined Arc - Left rear track centerline to right rear track centerline. Capacities appearing above bold line are based on structural strength and tipping should not be relied upon as a capacity limitation.
Capacities do not exceed 85% of tipping loads as determined by test in accordance with SAE J-765.
All lifting depends on proper tire inflation, capacity and condition. Chart based on 18.00 x 22.5 (18 ply rated) bias ply tires at 100 PSI cold inflation pressure. Loads must be reduced for lower tire inflation.
Capacities are applicable only with machine on a firm level surface.
22 ft. boom extension not permitted for on rubber lifts.
No loads to be lifted with main boom below 100° boom angle.
(7) For 2.5 MPH pick and carry operation, boom must be centered over rear of machine and mechanical swing lock engaged. (Engaging mechanical swing lock with boom centered over rear, automatically overrides the front axle lockouts).
Axle lockouts must be engaged before lifting on rubber. (Check automatic lockout system for proper functioning; refer to "Operation and Maintenance Manual" for description of a proper functioning axle lockout system).

WEIGHT REDUCTIONS FOR LOAD HANDLING DEVICES

†22 ft. BOOM EXT. WITH 29-70 ft. BOOM	
Stowed	450 lbs.
Erected	2,200 lbs.

HOOK BLOCKS	
25 Ton, 4 Sheave	605 lbs.
25 Ton, 3 Sheave	550 lbs.
5 Ton, Headache Ball	150 lbs.
7 1/2 Ton, Headache Ball	300 lbs.

NOTE: All load handling devices and boom attachments are considered part of the load and suitable allowances MUST BE MADE for their combined weights. Weights are for Grove furnished equipment.

†Reduction of main boom lifting capacities.

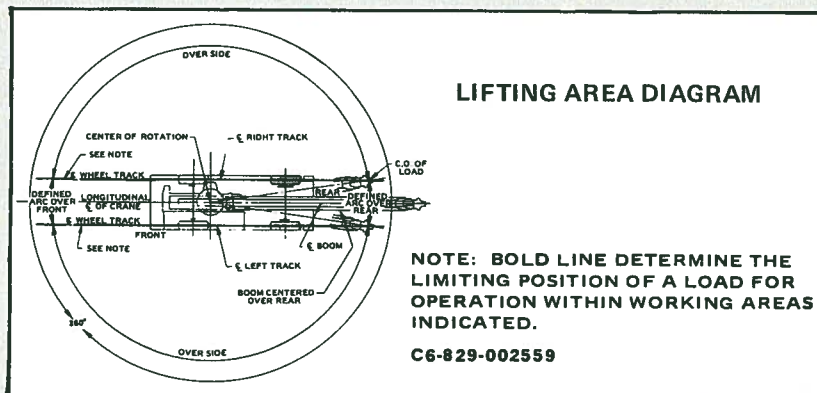

GROVE MANUFACTURING COMPANY
Division of Walter Kidde & Company, Inc.
KIDDE

Box 21, Shady Grove, Pennsylvania 17256

Distributed by: