

Series **500E2**

product guide

features

- **71' (21.6 m) Three-Section Boom**
- **18 USt (16.3 t) Rating**
- **Easy Glide Wear Pads**
- **Internal Anti-two-block**
- **Auxiliary Stabilizers**

contents

Features

2

Mounting Configurations

3

Specifications

4

Capacities

5

Accessories

9

Dimensions Specifications

10



features

Why Buy a National Series 500E2?

2



- **18 USt (16.3 t) Rating** – The new 500E2 provides an 18 USt (16.3 t) capacity.
- **New 71 ft. (21.6 m) Three-Section Boom** – The longest in its size range. The longer boom allows the operator to perform more lifts without the use of a jib, reducing setup time and improving efficiency.
- **Easy Glide Wear Pads** – The self-lubricating pads, standard on the 500E2 reduce the conditions that cause boom chatter and vibration. The net result is smoother crane operation.
- **Internal Anti-two-block** – The patent-pending design, standard on the 500E2 eliminates the external reel and wire. No more snagging reel or wire on obstructions.
- **Adjustable Swing Speed** – A control knob located on the swing motor brake release valve can be easily adjusted to the crane operator's swing speed preference.
- **Optional New Integral Steel Torsion Bedbox** – Integral welded torsion box and flatbed. Further reduces frame flex.
- **Auxiliary Stabilizers** –
 - Independent stabilizer control
 - Bolt/Clamp on rear stabilizers
- **Quick-reeve Boom Tip and Sheave Blocks** – These standard features simplify rigging changes.
- **Pre-painted Components** – Painting crane components before assembly reduces the possibility of rust, improves serviceability and enhances the appearance of the machine.
- **Electronic versions of manuals available through Manitowoc Crane CARE.**
- **Improved Serviceability** –
 - A removable winch allows the internal telescoping cylinder to be removed quickly, without dismantling the boom.
 - Bearings on the boom extend and retract cables can be greased through access holes in the boom side plates.
 - Internal anti-two-block wire routing eliminates damage potential.
 - The boom sheave case is open, allowing access to replace the internal anti-two-block wire and to observe internal boom components.
 - Pre-paint reduces rust.
 - Internal boom parts have been reduced, decreasing service time when rebuilding the machine.
- **National Crane Is the Market Leader** – National is number one in the production of commercial truck-mounted boom trucks, with more than 35,000 units sold. National has many programs and people directly and indirectly involved to provide our customers with reliable products.
 - National has the boom truck industry's leading test program. Every structural part of the crane is fully life cycle tested at full capacity. In addition to cycle testing, each model is subjected to state-of-the-art strain gauge testing that measures metal deformation as small as one-millionth of an inch. The net result is that weak areas are caught in test, not on job sites where costly downtime occurs.
 - All outrigger, lift and telescoping cylinders are manufactured to National Crane Designs, so that the seals, packing glands, and end plates are traced for accurate shipment of replacement parts.
 - National has a formalized quality program and is ISO 9001 approved.
 - Parts are available for all National Crane machines for the life of the crane.

- 18 USt (16.3 t) maximum capacity
- 121 ft. (36.9 m) maximum vertical reach*
- 81 ft. (24.7 m) maximum vertical hydraulic reach*
- Hydraulic Capacity Alert system (HCA)
- Proportional boom extension
- High performance planetary winch

* Maximum vertical reach is ground-level to boom tip height at maximum extension and angle with outriggers/stabilizers fully extended.

500E2

mounting configurations

The configurations are based on the Series 500E2 with an 85% stability factor. The complete unit must be installed in accordance with factory requirements and a test performed to determine actual stability and counterweight requirements since individual truck chassis vary.

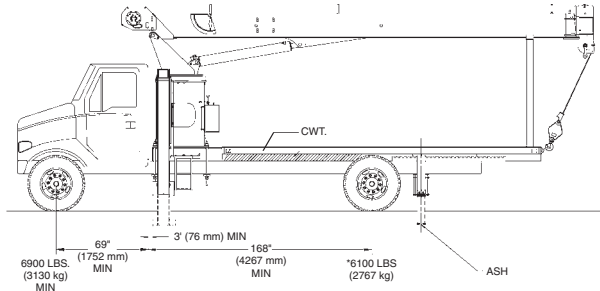

Configuration 1 with Torsion Box – 180° Full Capacity Work Area

Working area	180°
Gross Axle Weight Rating Front	12,000 lb (5443 kg)
Gross Axle Weight Rating Rear	21,000 lb (9525 kg)
Gross Vehicle Weight Rating	33,000 lb (14,968 kg)
Wheelbase	237 in (602 cm)
Cab to Axle/trunnion (CA/CT)	168 in (427 cm)
Frame Section Modulus (SM) under crane:	
110,000 PSI (758 MPa)	15.9 in ³ (261 cm ³)
Frame Section Modulus (SM) over rear stabilizers:	
110,000 PSI (758 MPa)	13 in ³ (213 cm ³)
Stability Weight, Front	6,900 lb (3130 kg) minimum*
Stability Weight, Rear	6,100 lb (2767 kg) minimum*
Estimated Average Final Weight	30,000 lb (13,608 kg)

This configuration is the least expensive method for the Model 571E2. This mount, with the crane mounted behind the cab, requires the least weight of all mounts for stability; thus, you can haul larger payloads on your truck. It requires standard subbase and rear (ASH) stabilizers.

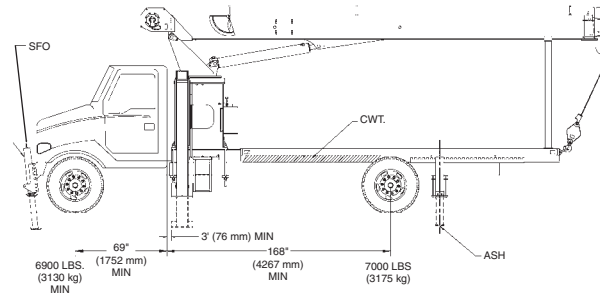

Configuration 2 with Torsion Box – 360° Full Capacity Work Area (Extended front frame rails required for SFO installation.)

Working area	360°
Gross Axle Weight Rating Front	12,000 lb (5443 kg)
Gross Axle Weight Rating Rear	21,000 lb (9525 kg)
Gross Vehicle Weight Rating	33,000 lb (14,968 kg)
Wheelbase	237 in (602 cm)
Cab to Axle/trunnion (CA/CT)	168 in (427 cm)
Frame Section Modulus (SM) under crane:	
110,000 PSI (758 MPa)	15.9 in ³ (261 cm ³)
Frame Section Modulus (SM) over rear stabilizers:	
110,000 PSI (758 MPa)	13 in ³ (213 cm ³)
Stability Weight, Front	6,900 lb (3130 kg) minimum*
Stability Weight, Rear	7,000 lb (3175 kg) minimum*
Estimated Average Final Weight	30,500 lb (13,835 kg)

Requires front SFO stabilizer to give machine full capacity 360° around the truck. Truck must meet the minimum requirements above. Front stabilizer gives the machine a solid base, helping the operator control loads precisely.

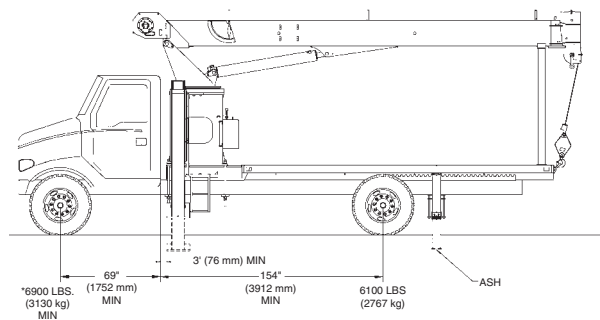

Configuration 3 with Torsion Box – 180° Full Capacity Work Area

Working area	180°
Gross Axle Weight Rating Front	12,000 lb (5443 kg)
Gross Axle Weight Rating Rear	21,000 lb (9,525 kg)
Gross Vehicle Weight Rating	33,000 lb (14,968 kg)
Wheelbase	223 in (566 cm)
Cab to Axle/trunnion (CA/CT)	154 in (391 cm)
Frame Section Modulus (SM) under crane:	
110,000 PSI (758 MPa)	15.9 in ³ (261 cm ³)
Frame Section Modulus (SM) over rear stabilizers:	
110,000 PSI (758 MPa)	13 in ³ (213 cm ³)
Stability Weight, Front	6,800 lb (3084 kg) minimum*
Stability Weight, Rear	5,500 lb (2494 kg) minimum*
Estimated Average Final Weight	28,750 lb (13,040 kg)

Allows the installation of the Model 560E2 on a chassis with a small frame by using the standard sub-base for 18' bed. In most cases, the chassis will not require reinforcing, and the amount of counterweight required is minimized, increasing payload capacities.

Notes:

- Gross Vehicle Weight rating (GVWR) is dependent on all components of the vehicle (axles, tires, springs, frame, etc.) meeting manufacturers' recommendations: always specify GVWR when purchasing trucks
- Diesel engines require a variable speed governor and energize-to-run fuel solenoid for smooth crane operation; electronic fuel injection requires EET engine remote throttle

- All mounting data is based on a National Series 500E2 with an 85 percent stability factor
- The complete unit must be installed in accordance with factory requirements, and a test performed to determine actual stability and counterweight requirements per SAE J765; contact the factory for details
- Transmission neutral safety interlock switch is required with optional remote control

*Estimated axle scale rates prior to installation of crane, stabilizers and subbase for 85% stability.

3

500E2

specifications

Boom and Jib Combinations Data

4

Available in two basic models.

Model 560E2 – Equipped with a 24-60 ft. (7.31-18.29 m) three-section boom. This model can be equipped with a 23-41 ft. (7.01-12.50 m) two-section jib. Maximum tip height w/41 ft. (12.50 m) jib is 110 ft. (33.53 m).

24-60 ft. (7.31-18.29 m) three-section boom. **5FJ41M** 23-41 ft. (7.01-12.50 m) two-section jib



Model 571E2 – Equipped with a 27-71 ft. (8.23-21.65 m) three-section boom. This model can be equipped with a 23-41 ft. (7.01-12.50 m) two-section jib. Maximum tip height w/41 ft. (12.50 m) jib is 121 ft. (36.9 m).

27-71 ft. (8.23-21.65 m) three-section boom. **5FJ41M** 23-41 ft. (7.01-12.50 m) two-section jib



Note: Maximum tip is measured with outriggers/stabilizers fully extended.

500E2 Winch Data

500E2 Winch Data

- All winch pulls and speeds in this chart are shown on the fourth layer
- Winch line pulls would increase on the first and second layers
- Winch line pulls may be limited by the winch capacity or the ANSI 5 to 1 cable safety factor, shown below this chart
- Hook blocks are rated at maximum capacity for the block. **Do not exceed rated cable pull with any block.**

500E2 Winch Data			1 Part Line	2 Part Line	3 Part Line	4 Part Line	5 Part Line	6 Part Line
<ul style="list-style-type: none"> • All winch pulls and speeds in this chart are shown on the fourth layer • Winch line pulls would increase on the first and second layers • Winch line pulls may be limited by the winch capacity or the ANSI 5 to 1 cable safety factor, shown below this chart • Hook blocks are rated at maximum capacity for the block. Do not exceed rated cable pull with any block. 								
Winch	Cable Supplied	Average Breaking Strength	Max. Pull	Max. Pull	Max. Pull	Max. Pull	Max. Pull	Max. Pull
Standard Planetary Winch	9/16" Diameter Rotation Resistant	38,500 lb (17,463 kg)	7,700 lb (3 492.66 kg)	15,400 lb (6 985.32 kg)	23,100 lb (10 477.98 kg)	30,800 lb (13 970.65 kg)	38,500 lb (14 514.96 kg)	40,000 lb (14 514.96 kg)

Layer	Winch Pull		Winch Speed		BOS Winch Speed		Rope Capacity	
	lbs	(kg)	fpm	(mpm)	fpm	(mpm)	ft	(m)
1	10,380	(4708)	157	(48)	222	(68)	64	19
2	9,360	(4246)	175	(53)	246	(75)	136	41
3	8,520	(3865)	192	(59)	271	(83)	215	65
4	7,820	(3547)	209	(64)	294	(90)	301	91
5	7,230	(3279)	257	(69)	318	(97)	394	120

NOTE: All ratings based on 34 GPM at 3300 psi (128.7 LPM at 22.75 MPa)
Burst of Speed maximum pull = 3000 lb (1361 kg)

500E2

Winch Bare Drum Pull Allowable Cable Pull
With standard rotation resistant rope10,200 lb (4627 kg)7,700 lb (3493 kg)

Block Type	Rating	Weight
Downhaul Weight	3.85 ton (3.49 t)	150 lb (68 kg)
1 Sheave Block	11.55 ton (10.48 t)	200 lb (91 kg)
2 Sheave Block	19.25 ton (17.46 t)	355 lb (161 kg)

capacities

5

Load Rating Chart: Series 560E2 (18.2 m) Boom with 41 ft. (12.5 m) Jib

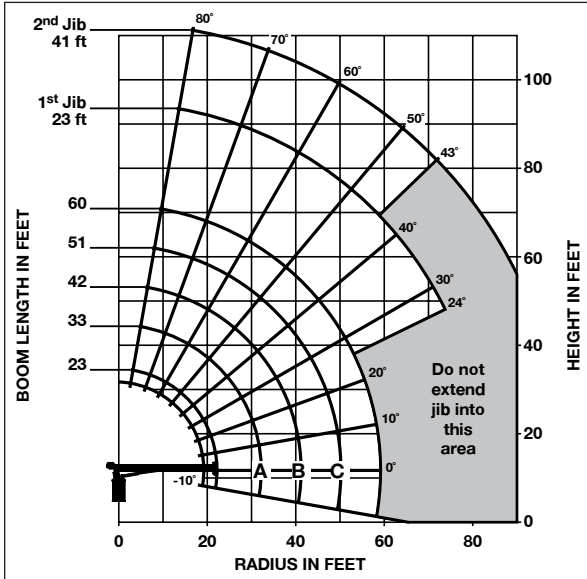

CAUTION:

- Do not operate crane booms, jib extensions, any accessories or loads within 10 ft (3m) of live power lines or other conductors of electricity.
- Jib and boom capacities shown are maximum for each section.
- Do not exceed capacities at reduced radii
- Load ratings shown on the load rating charts are maximum allowable loads with the outriggers properly extended on a firm, level surface and the crane leveled and mounted on a factory recommended truck.
- Always level the crane with the level indicator located on the crane.
- The operator must reduce load to allow for factors such as wind, ground conditions, operating speeds and their effects on freely suspended loads.
- Overloading this crane may cause structural collapse or instability.
- Weights on any accessories attached to the boom or loadline must be deducted from the load chart capacities.
- Do not exceed jib capabilities at any reduced boom lengths.
- Do not deadhead lineblock against boom tip when extending boom or winching up.
- Keep at least three wraps of loadline on drum at all times.
- Use only specified cable with this machine.
- Shaded areas are structurally limited capacities.

**SERIES 560E2
WITH 41' JIB**

**LOADLINE EQUIPMENT
DEDUCT**
Downhaul weight.....150 lb (68kg)
One sheave block200 lb (91kg)
Two sheave block355 lb (161kg)

Load Rating Chart: Series 560E2 (18.2 m) Boom with 41 ft. (12.5 m) Jib

LOADED RADIUS (ft)	LOADED BOOM ANGLE (deg)	23 FT BOOM (lb)	LOADED BOOM ANGLE (deg)	A 33 FT BOOM (lb)	LOADED BOOM ANGLE (deg)	B 42 FT BOOM (lb)	LOADED BOOM ANGLE (deg)	C 51 FT BOOM (lb)	LOADED BOOM ANGLE (deg)	60 FT BOOM (lb)	LOADED BOOM ANGLE (deg)	23 FT JIB (lb)	LOADED BOOM ANGLE (deg)	41 FT JIB (lb)	
5	75	36,000													
8	67	22,500	74	20,950											
10	61.5	18,900	70	18,050	75	17,500									
12	56	16,200	66.5	15,550	72.5	15,000	76	14,400							
14	50.5	14,100	63	13,650	69	13,150	74	12,600	77	10,950					
16	42	12,300	58.5	12,100	66.5	11,650	71.5	11,200	75.5	10,250					
20	23	8,700	50	9,800	60	9,500	66.5	9,150	71	8,700	76	3,450			
25			37.5	7,600	52.5	7,650	60.5	7,350	66	7,200	72.5	2,850	76.5	2,150	
30			17	5,050	43	6,200	53.5	6,100	60.5	6,000	68	2,400	73.5	1,950	
35					31	4,900	46	5,100	54.5	5,050	65	2,050	70.5	1,600	
40					8	2,700	37	4,200	48.5	4,300	61	1,750	67.5	1,350	
45								25.5	3,300	41	3,650	57	1,500	64.5	1,200
50										32.5	3,000	53	1,300	61.5	1,050
55										21	2,250	48.5	1,150	58	900
60												43.5	1,000	54.5	800
65												38	850	51	700
70												32	750	47	600
75												24	600	43	500
	0	4,600	0	2,900	0	1,950	0	1,300	0	850					

THIS CHART IS ONLY A GUIDE AND SHOULD NOT BE USED TO OPERATE THE CRANE. The individual crane's load chart, operating instructions and other instructional plates must be read and understood prior to operating the crane.

capacities

Load Rating Chart: Series 560E2 (18.2 m) Boom

6

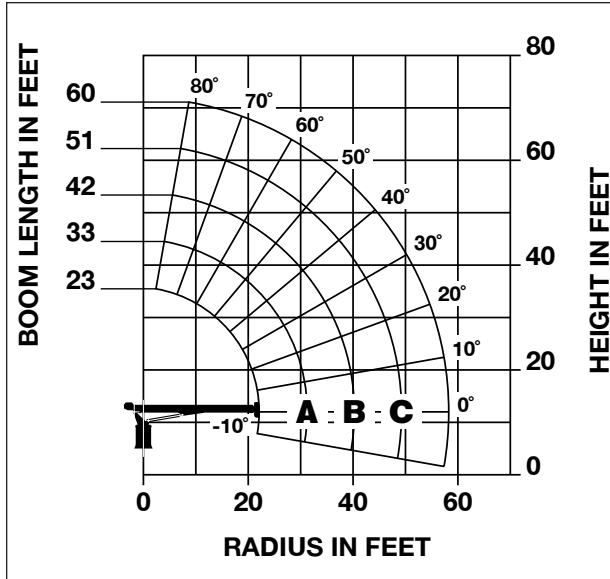

CAUTION:

- Do not operate crane booms, jib extensions, any accessories or loads within 10 ft (3m) of live power lines or other conductors of electricity.
- Jib and boom capacities shown are maximum for each section.
- Do not exceed capacities at reduced radii
- Load ratings shown on the load rating charts are maximum allowable loads with the outriggers properly extended on a firm, level surface and the crane leveled and mounted on a factory recommended truck.
- Always level the crane with the level indicator located on the crane.
- The operator must reduce load to allow for factors such as wind, ground conditions, operating speeds and their effects on freely suspended loads.
- Overloading this crane may cause structural collapse or instability.
- Weights on any accessories attached to the boom or load-line must be deducted from the load chart capacities.
- Do not exceed jib capabilities at any reduced boom lengths.
- Do not deadhead lineblock against boom tip when extending boom or winching up.
- Keep at least three wraps of loadline on drum at all times.
- Use only specified cable with this machine.
- Capacities do not exceed 85% stability.
- Shaded areas are structurally limited capacities.

**SERIES 560E2 /
NO JIB**

LOADLINE EQUIPMENT DEDUCT

Downhaul weight.....150 lb (68kg)
One sheave block200 lb (91kg)
Two sheave block355 lb (161kg)

Load Rating Chart: Series 560E2 (18.2 m) Boom

LOADED RADIUS (ft)	LOADED BOOM ANGLE (deg)	23 FT BOOM (lb)	LOADED BOOM ANGLE (deg)	A 33 FT BOOM (lb)	LOADED BOOM ANGLE (deg)	B 42 FT BOOM (lb)	LOADED BOOM ANGLE (deg)	C 51 FT BOOM (lb)	LOADED BOOM ANGLE (deg)	60 FT BOOM (lb)
5	75	36,000								
8	67	23,150	74	21,350						
10	61.5	19,550	70	18,500	75	17,850				
12	56	16,900	66.5	16,000	72.5	15,350	76	14,700		
14	50.5	14,750	63	14,100	69	13,500	74	12,900	77	11,200
16	42	12,950	58.5	12,605	66.5	12,050	71.5	11,500	75.5	10,500
20	23	9,400	50	10,250	60	9,850	66.5	9,400	71	9,000
25			37.5	8,050	52.5	8,000	60.5	7,650	66	7,450
30			17	5,550	43	6,550	53.5	6,400	60.5	6,200
35					31	5,250	46	5,400	54.5	5,300
40					8	3,050	37	4,500	48.5	4,550
45							25	3,600	41	3,900
50									32.5	3,300
55									21	2,500
	0	5,300	0	3,350	0	2,300	0	1,600	0	1,100

500E2

THIS CHART IS ONLY A GUIDE AND SHOULD NOT BE USED TO OPERATE THE CRANE. The individual crane's load chart, operating instructions and other instructional plates must be read and understood prior to operating the crane.

capacities

7

Load Rating Chart: Series 571E2 (21.6 m) Boom with 41 ft. (12.5 m) Jib

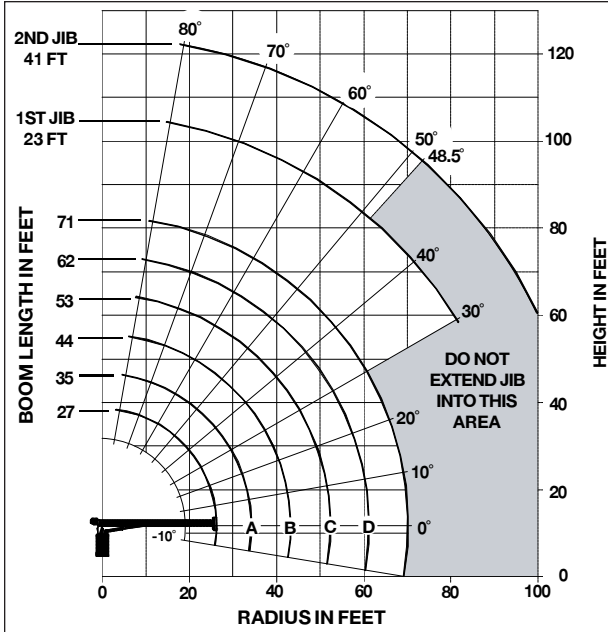

CAUTION:

- Do not operate crane booms, jib extensions, any accessories or loads within 10 ft (3m) of live power lines or other conductors of electricity.
- Jib and boom capacities shown are maximum for each section.
- Do not exceed capacities at reduced radii
- Load ratings shown on the load rating charts are maximum allowable loads with the outriggers properly extended on a firm, level surface and the crane leveled and mounted on a factory recommended truck.
- Always level the crane with the level indicator located on the crane.
- The operator must reduce load to allow for factors such as wind, ground conditions, operating speeds and their effects on freely suspended loads.
- Overloading this crane may cause structural collapse or instability.
- Weights on any accessories attached to the boom or load-line must be deducted from the load chart capacities.
- Do not exceed jib capabilities at any reduced boom lengths.
- Do not deadhead lineblock against boom tip when extending boom or winching up.
- Keep at least three wraps of loadline on drum at all times.
- Use only specified cable with this machine.
- Shaded areas are structurally limited capacities.

NOTE:

1. Operate with jib by radius when main boom is fully extended. If necessary increase boom angle to maintain loaded radius.
2. Operate with jib by boom angle when main boom is not fully extended. Do not exceed rated jib capacities at any reduced boom lengths.

**SERIES 571E2
WITH 41' JIB**

LOADLINE EQUIPMENT DEDUCT	
Downhaul weight.....	150 lb (68kg)
One sheave block	200 lb (91kg)
Two sheave block	355 lb (161kg)

Load Rating Chart: Series 571E2 (21.6 m) Boom with 41 ft. (12.5 m) Jib

LOAD RATINGS IN POUNDS

LOAD RADIUS (FEET)	LOADED BOOM ANGLE	27 FT BOOM	LOADED BOOM ANGLE	A 35 FT BOOM	LOADED BOOM ANGLE	B 44 FT BOOM	LOADED BOOM ANGLE	C 53 FT BOOM	LOADED BOOM ANGLE	D 62 FT BOOM	LOADED BOOM ANGLE	71 FT BOOM	LOAD RADIUS (FEET)	LOADED BOOM ANGLE	23 FT JIB	LOADED BOOM ANGLE	41 FT JIB
5	77.5	36,000											20	77	3,400		
8	70.5	24,050	75.5	20,100									25	74.3	2,900	77.3	2,050
10	66	18,900	72	16,800	76.5	16,300	79.5	16,050					30	70.6	2,450	74.5	1,800
12	61	15,650	68.5	14,400	73.5	13,950	77	13,700					35	67.5	2,100	72.2	1,550
14	56	13,650	64.5	12,600	71	12,200	75	11,950	77.5	11,750			40	64.1	1,800	69.5	1,400
16	50.5	12,000	61	11,150	68	10,800	72.5	10,550	75.5	10,400	78	9,350	45	60.3	1,600	66.4	1,200
20	37.5	9,350	53	9,000	62	8,750	68	8,550	72	8,400	75	7,750	50	57.5	1,450	63.4	1,050
25	14	5,700	41	7,000	55	6,950	62	6,850	67	6,700	70.5	6,500	55	53.8	1,250	60.9	950
30			26.5	5,200	46	5,660	55.5	5,650	62	5,550	66.5	5,450	60	49.8	1,100	57.8	850
35					35.5	4,500	48.5	4,700	56.5	4,650	61.5	4,550	65	46	950	55.2	750
40					20	3,200	40.5	3,850	50.5	3,950	57	3,850	70	41.6	850	51.7	600
45							30.5	3,100	43.5	3,300	51.5	3,300	75	36.6	750	48.1	500
50							14	2,000	36	2,750	46	2,800	80	31	650		
55									26	2,150	39.5	2,350					
60											32	1,950					
65											22.5	1,400					
	0	3,500	0	2,200	0	1,350	0	900	0	500							

THIS CHART IS ONLY A GUIDE AND SHOULD NOT BE USED TO OPERATE THE CRANE. The individual crane's load chart, operating instructions and other instructional plates must be read and understood prior to operating the crane.

capacities

Load Rating Chart: Series 571E2 (21.6 m) Boom

8

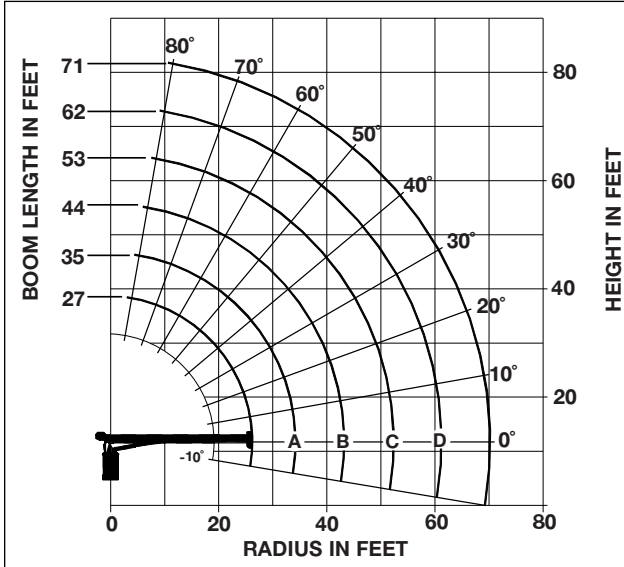

CAUTION:

- Do not operate crane booms, jib extensions, any accessories or loads within 10 ft (3m) of live power lines or other conductors of electricity.
- Jib and boom capacities shown are maximum for each section.
- Do not exceed capacities at reduced radii
- Load ratings shown on the load rating charts are maximum allowable loads with the outriggers properly extended on a firm, level surface and the crane leveled and mounted on a factory recommended truck.
- Always level the crane with the level indicator located on the crane.
- The operator must reduce load to allow for factors such as wind, ground conditions, operating speeds and their effects on freely suspended loads.
- Overloading this crane may cause structural collapse or instability.
- Weights on any accessories attached to the boom or loadline must be deducted from the load chart capacities.
- Do not exceed jib capabilities at any reduced boom lengths.
- Do not deadhead lineblock against boom tip when extending boom or winching up.
- Keep at least three wraps of loadline on drum at all times.
- Use only specified cable with this machine.
- Shaded areas are structurally limited capacities.

**SERIES 571E2/
NO JIB**

LOADLINE EQUIPMENT DEDUCT

Downhaul weight.....150 lb (68kg)
One sheave block200 lb (91kg)
Two sheave block355 lb (161kg)

Load Rating Chart: Series 571E2 (21.6 m) Boom

LOAD RADIUS (FEET)	LOADED BOOM ANGLE	27 FT BOOM	LOADED BOOM ANGLE	A 35 FT BOOM	LOADED BOOM ANGLE	B 44 FT BOOM	LOADED BOOM ANGLE	C 53 FT BOOM	LOADED BOOM ANGLE	D 62 FT BOOM	LOADED BOOM ANGLE	71 FT BOOM
5	77.5	36,000										
8	70.5	24,650	75.5	20,550								
10	66	19,500	72	17,250	76.5	16,700	79.5	16,350				
12	61	16,250	68.5	14,850	73.5	14,350	77	14,000				
14	56	14,250	64.5	13,050	71	12,600	75	12,250	77.5	12,000		
16	50.5	12,600	61	11,600	68	11,200	72.5	10,850	75.5	10,650	78	9,600
20	37.5	9,950	53	9,450	62	9,150	68	8,850	72	8,650	75	8,000
25	14	6,300	41	7,450	55	7,350	62	7,150	67	6,950	70.5	6,750
30			26.5	5,650	46	6,060	55.5	5,950	62	5,800	66.5	5,700
35					35.5	4,900	48.5	5,000	56.5	4,900	61.5	4,800
40					20	3,600	40.5	4,150	50.5	4,200	57	4,100
45							30.5	3,400	43.5	3,550	51.5	3,550
50							14	2,300	36	3,000	46	3,050
55									26	2,400	39.5	2,600
60											32	2,200
65											22.5	1,650
	0	4,100	0	2,650	0	1,750	0	1,200	0	750	0	400

THIS CHART IS ONLY A GUIDE AND SHOULD NOT BE USED TO OPERATE THE CRANE. The individual crane's load chart, operating instructions and other instructional plates must be read and understood prior to operating the crane.

500E2

Radio Remote Controls –

Eliminate the handling and maintenance concerns that accompany cabled remotes. Operate to a range of about 250 feet (76 m), varying with conditions.

- RB4R (R4 functions)

One-Person Basket –

Strong but lightweight steel basket with 300-lb. (139-kg) capacity, gravity hung with swing lock and full body harness.

- B1-S
- 2B1-S (for dual locking baskets)

Heavy-duty Personnel Basket –

1,200-lb. (544-kg) capacity steel basket with safety loops for four passengers. Gravity leveling 72- x 42-inch (183- x 107-cm) platform. Fast attachment and secure locking systems. Load chart must show 2,300 (1043 kg) minimum to operate this accessory.

- BSA-1
- BSA-R1 (provides rotation)

Hydraulic Oil Cooler –

Automatic, self-contained radiator system with electric fans, cools oil under continuous duty-cycle operations.

- OC

Single Front Outrigger –

Center mount front stabilizer with 25" vertical stroke.

- SFO

Burst-of-Speed Winch –

Provides faster winch payout and pickup of unloaded cable.

- BOS

Outrigger Motion Alarms –

Available for "A" frame O/R and ASH stabilizers.

- OMA-1

Hour Meter –

Hour meter in truck cab to record crane operation hours.

- HRM

Bulkhead Options –

Steel 30" solid wall bulkhead.

- BHSI
- BHSD

Steel Tool Box Options –

Spanish-Language Danger Decals, Control Knobs, and Operators' Manuals –

- SDD
- SOM

dimensions specifications

Dimensions Specifications

MAINTAIN CLEARANCE FOR R45.00 [R1144] TAILSWING

ALL DIMENSIONS IN INCHES (MM) UNLESS OTHERWISE SPECIFIED

SERIES	RETRACTED LENGTH	EXTENDED LENGTH	G (WET) INCHES (m)	DRY/WET lb (kg)	WITH OIL/WT lb (kg)
560E2	23'10"	60'	63 (1.60)	13,582 (6,136)*	14,123 (6,406)*
571E2	27'6"	71'	75 (1.91)	14,721 (6,677)**	15,316 (6,947)**
571E2	27'6"	71'	78 (1.98)	15,851 (7,190)**	16,446 (7,460)***

*INCLUDES STANDARD 18' SUBBASE
 **INCLUDES STANDARD 20' SUBBASE
 ***INCLUDES 20' INTEGRAL BED/T-BOX

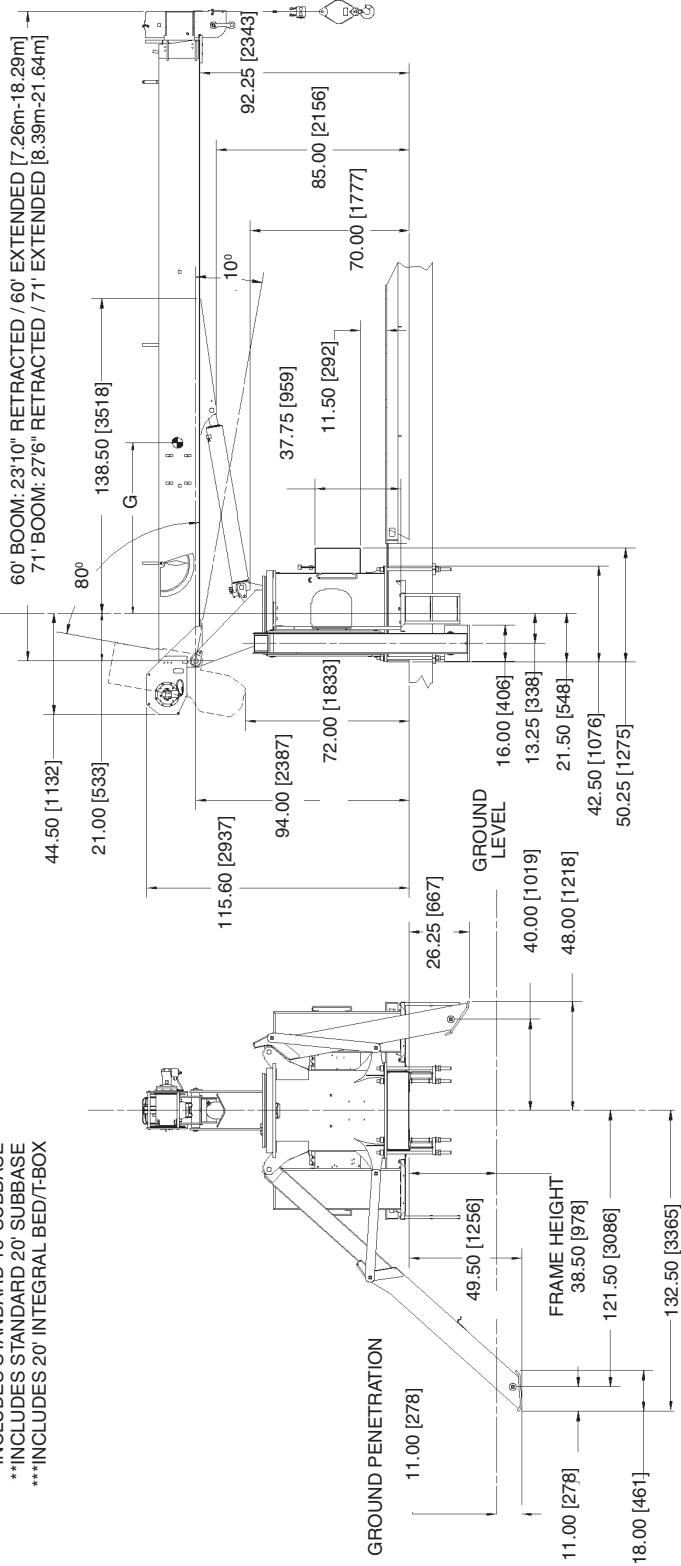

Regional Headquarters

Americas

Manitowoc, Wisconsin, USA

Tel: +1 920 684 6621

Fax: +1 920 683 6278

Shady Grove, Pennsylvania, USA

Tel: +1 717 597 8121

Fax: +1 717 597 4062

Regional Offices

Americas

Brazil

Alphaville

Tel: +55 11 3103 0200

Fax: +55 11 4688 2013

Mexico

Monterrey

Tel: +52 81 8124 0128

Fax: +52 81 8124 0129

Europe, Middle East, Africa

Algeria

Hydra

Tel: +21 3 21 48 1173

Fax: +21 3 21 48 1454

Czech Republic

Netvorice

Tel: +420 317 78 9313

Fax: +420 317 78 9314

France

Baudemont

Tel: +33 385 28 2589

Fax: +33 385 28 0430

Cergy

Tel: +33 130 31 3150

Fax: +33 130 38 6085

Decines

Tel: +33 472 81 5000

Fax: +33 472 81 5010

Germany

Langenfeld

Tel: +49 21 73 8909-0

Fax: +49 21 73 8909 30

Hungary

Budapest

Tel: +36 13 39 8622

Fax: +36 13 39 8622

Italy

Parabiago

Tel: +390 331 49 3311

Fax: +390 331 49 3330

Europe, Middle East, Africa

Ecully, France

Tel: +33 472 18 2020

Fax: +33 472 18 2000

Netherlands

Breda

Tel: +31 76 578 3999

Fax: +31 76 578 3978

Poland

Warsaw

Tel: +48 22 843 3824

Fax: +48 22 843 3471

Portugal

Alfena

Tel: +351 229 69 8840

Fax: +351 229 69 8848

Lisbon

Tel: +351 212 109 340

Fax: +351 212 109 349

Russia

Moscow

Tel: +7 495 641 2359

Fax: +7 495 641 2358

U.A.E.

Dubai

Tel: +971 4 3381 861

Fax: +971 4 3382 343

U. K.

Middlesex

Tel: +44 1 895 43 0053

Fax: +44 1 895 45 9500

Sunderland

Tel: +44 191 522 2000

Fax: +44 191 522 2052

Asia – Pacific

Australia

Melbourne

Tel: +61 3 9 336 1300

Fax: +61 3 9 336 1322

Sydney

Tel: +61 2 9 896 4433

Fax: +61 2 9 896 3122

Asia – Pacific

Shanghai, China

Tel: +86 21 51113579

Fax: +86 21 51113578

Singapore

Tel: +65 6264 1188

Fax: +65 6862 4142

China

Beijing

Tel: +86 10 58674761

Fax: +86 10 58674760

Xi'an

Tel: +86 29 87891465

Fax: +86 29 87884504

Korea

Seoul

Tel: +82 2 3439 0400

Fax: +82 2 3439 0405

Philippines

Makati City

Tel: +63 2 844 9437

Fax: +63 2 844 4712

Factories

Brazil

Alphaville

China

Zhangjiagang

France

Charlieu

La Clayette

Moulins

Germany

Wilhelmshaven

India

Calcutta

Pune

Italy

Niella Tanaro

Portugal

Baltar

Fânzeres

Slovakia

Saris

U.S.A.

Manitowoc

Port Washington

Shady Grove

Constant improvement and engineering progress make it necessary that we reserve the right to make specification, equipment and price changes without notice. Illustrations shown may include optional equipment and accessories, and may not include all standard equipment.