

National Crane Series 800D

Product Guide

Features

- 20,87 t (23 USt) rating
- 30,48 m (100 ft) four-section boom
- Self-lubricating "Easy Glide" wear pads
- Internal Anti-Two Block



Features



Four-section boom

At 30,48 m (100 ft) the Series 800D boom is the longest in its size range. The longer boom allows the operator to perform more lifts without the use of a jib, reducing setup time and improving efficiency.

Overload protection

All National Crane boom trucks are equipped with overload protection. A Load Moment Indicator (LMI) is required on all machines equipped with jibs or personnel baskets.



Optional auger attachment

Available on the 890D only, the 14,000 ft/lb two-speed auger attachment has a maximum digging radius of 39 ft.

National Crane Series 800D

- 20,87 t (23 USt) maximum capacity
- 46,32 m (152 ft) maximum vertical reach
- 33,22 m (109 ft) maximum vertical hydraulic reach

Boom tip

The speedy-reeve boom tip and sheave blocks simplify rigging changes. Load line wedge socket removal is not required for reeving of multi-part line options.



Easy Glide boom wear pads

These wear pads reduce the conditions that cause boom chatter and vibration resulting in smoother crane operation.

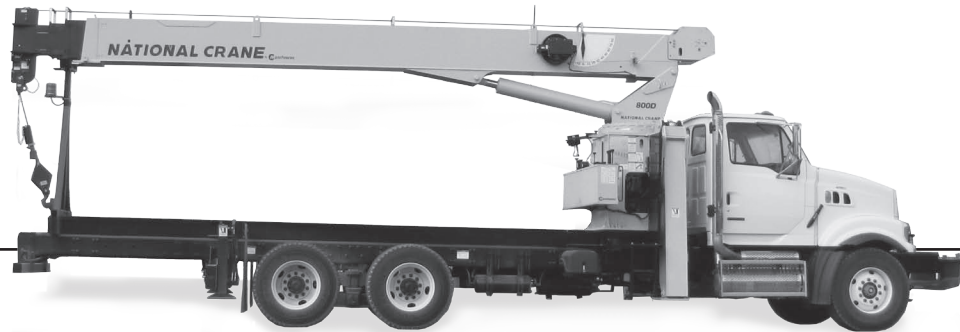

Best in class performance and serviceability

- The stronger standard torsion box improves rigidity, reduces truck frame flex and reduces the need for counterweight.
- Painting crane components before assembly reduces the possibility of rust, improves serviceability and enhances the appearance of the machine.
- State of the art control valve provides smoother operation. This design eliminates parts, reducing repair costs and improving the machines serviceability.
- Sheave bearings on the boom and retract cables can be greased through access holes in the boom side plates and the number of internal boom parts has been reduced to improve serviceability.
- Burst of Speed winch provides faster winch payout and pickup of unloaded cable.
- Adjustable swing speed is standard on the Series 800D. A control knob located on the swing motor brake release valve can be easily adjusted to the crane operator's swing speed preference.
- Internal anti-two block wire comes standard. It routes the wire through the inside of the boom eliminating the possibility of snagging the wire on obstructions.

Contents

Mounting configurations	5
Specifications	6
Capacities	8
Dimensions	13
Accessories	14

Mounting configurations

The configurations are based on the Series 800D with an 85% stability factor. The complete unit must be installed in accordance with factory requirements and a test performed to determine actual stability and counterweight requirements since individual truck chassis vary. Trucks with a frame height in excess of 107 cm (42 in) after mounting will have a final mounted unit height more than 411.5 cm (13 ft 6 in). Chassis that do not meet these minimum stability weights may require counterweight.

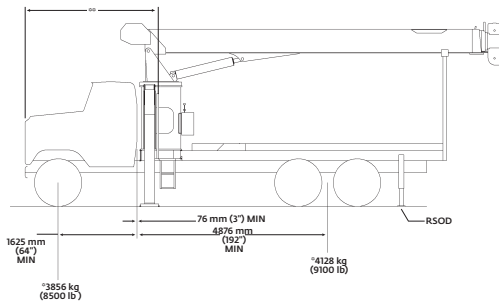

Configuration 1 – 8100D

Working area	180'
Gross Axle Weight Rating Front	7257 kg (16,000 lb)
Gross Axle Weight Rating Rear	15 422 kg (34,000 lb)
Gross Vehicle Weight Rating	22 679 kg (50,000 lb)
Wheelbase	650 cm (256 in)
Cab to Axle/trunnion (CA/CT)	488 cm (192 in)
Frame Section Modulus (SM) under crane: 758 MPa (110,000 PSI)	260.6 cm ³ (15.9 in ³)
Frame Section Modulus (SM) over rear stabilizers: 758 MPa (110,000 PSI)	213.0 cm ³ (13.0 in ³)
Stability Weight, Front	3856 kg (8500 lb) minimum*
Stability Weight, Rear	4128 kg (9100 lb) minimum*
Estimated Average Final Weight	18 507 kg (40,800 lb)

This configuration allows the installation of the Series 8100D on a chassis by using the subbase for a 6,71 m (22 ft) bed.

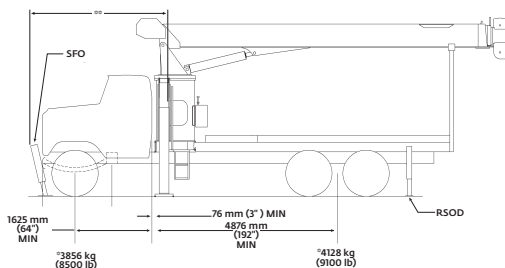

Configuration 2 – 8100D (add SFO for 360° stability)

Working area	360'
Gross Axle Weight Rating Front	7257 kg (16,000 lb)
Gross Axle Weight Rating Rear	15 422 kg (34,000 lb)
Gross Vehicle Weight Rating	22 679 kg (50,000 lb)
Wheelbase	650 cm (256 in)
Cab to Axle/trunnion (CA/CT)	488 cm (192 in)
Frame Section Modulus (SM) under crane: 758 MPa (110,000 PSI)	327.7 cm ³ (20.0 in ³)
Frame Section Modulus (SM) over rear stabilizers: 758 MPa (110,000 PSI)	213.0 cm ³ (13.0 in ³)
Stability Weight, Front	3856 kg (8500 lb) minimum*
Stability Weight, Rear	4128 kg (9100 lb) minimum*
Estimated Average Final Weight	18 688 kg (41,200 lb)

This mount requires front stabilizer for full capacity 360° around the truck. Front stabilizer gives the machine a solid base. This configuration requires a 6,71 m (22 ft) bed for rear overhang, and extended front frame rails for SFO mounting. NOTE: Chassis will require extended front frame rails for SFO mounting.

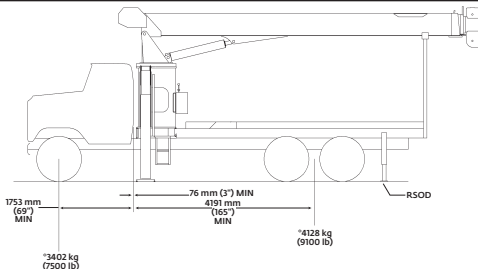

Configuration 3 – All boom lengths, other than 8100D

Working area	180'
Gross Axle Weight Rating Front	7257 kg (16,000 lb)
Gross Axle Weight Rating Rear	15 422 kg (34,000 lb)
Gross Vehicle Weight Rating	22 679 kg (50,000 lb)
Wheelbase	594 cm (234 in)
Cab to Axle/trunnion (CA/CT)	419 cm (165 in)
Frame Section Modulus (SM) under crane w/ 758 MPa (110,000 PSI)	260.6 cm ³ (15.9 in ³)
Frame Section Modulus (SM) over rear stabilizers: 758 MPa (110,000 PSI)	213.0 cm ³ (13.0 in ³)
Stability Weight, Front	3402 kg (7500 lb) minimum*
Stability Weight, Rear	4128 kg (9100 lb) minimum*
Estimated Average Final Weight (890D)	17 600 kg (38,800 lb)**

This configuration allows the installation of the Series 800D on a chassis with a subbase and bed combination which best fits the boom length. Depending on the boom length, the bed can be 18 ft, 20 ft or 22 ft. Not all bed lengths can be used with each boom due to rear overhang limits.

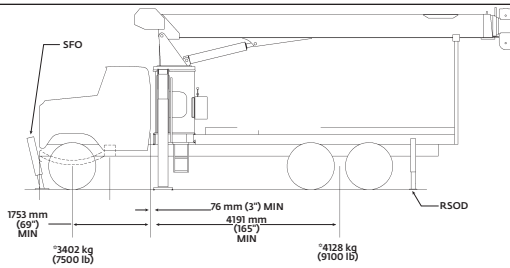

Configuration 4 – All boom lengths, other than 8100D

Working area	360'
Gross Axle Weight Rating Front	7257 kg (16,000 lb)
Gross Axle Weight Rating Rear	15 422 kg (34,000 lb)
Gross Vehicle Weight Rating	22 679 kg (50,000 lb)
Wheelbase	594 cm (234 in)
Cab to Axle/trunnion (CA/CT)	419 cm (165 in)
Frame Section Modulus (SM) under crane w/ 758 MPa (110,000 PSI)	327.7 cm ³ (20 in ³)
Frame Section Modulus (SM) over rear stabilizers: 758 MPa (110,000 PSI)	213.0 cm ³ (13 in ³)
Stability Weight, Front	3402 kg (7500 lb) minimum*
Stability Weight, Rear	4128 kg (9100 lb) minimum*
Estimated Average Final Weight (890D)	17 780 kg (39,200 lb)

This mount requires front stabilizer for full capacity 360° around the truck. Front stabilizer gives the machine a solid base. Bed length and subbase combinations must match boom length to limit rear overhang. Extended front frame rails required for SFO mounting. NOTE: Chassis will require extended front frame rails for SFO mounting.

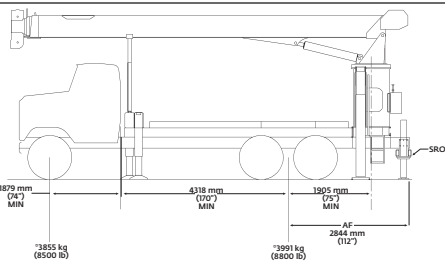

Configuration 5 – Rear Mount (all boom lengths)

Working area	360'
Gross Axle Weight Rating Front	7257 kg (16,000 lb)
Gross Axle Weight Rating Rear	18 143 kg (40,000 lb)
Gross Vehicle Weight Rating	25 401 kg (56,000 lb)
Wheelbase	620 cm (244 in)
Cab to Axle/trunnion (CA/CT)	432 cm (170 in)
Frame Section Modulus (SM) under crane: 758 MPa (110,000 PSI)	260.6 cm ³ (15.9 in ³)
Stability Weight, Front	3856 kg (8500 lb) minimum*
Stability Weight, Rear	3991 kg (8800 lb) minimum*
Estimated Average Final Weight (8100D)	19 504 kg (43,000 lb)

This configuration allows the rear-mount installation of the Series 800D. This configuration is 360° stable and allows the effective use of close working area to lift the heavier capacity loads. Maximum bed length is 4,87 m (16 ft). Requires single rear outrigger.

Notes:

- Gross Vehicle Weight rating (GVWR) is dependent on all components of the vehicle (axles, tires, springs, frame, etc.) meeting manufacturers' recommendations; always specify GVWR when purchasing trucks
- Diesel engines require a variable speed governor and energize-to-run fuel solenoid for smooth crane operation; electronic fuel injection requires EET engine remote throttle

- All mounting data is based on a National Series 800D with an 85 percent stability factor
- The complete unit must be installed in accordance with factory requirements, and a test performed to determine actual stability and counterweight requirements per SAE J765; contact the factory for details
- Transmission neutral safety interlock switch is required

*Estimated axle scale weights prior to installation of crane, stabilizers and subbase for 85% stability.

**If the distance from the front bumper (SFO) to center of rotation exceeds 366 cm (144 in), the 12,19 m (40 ft) overall truck length restriction will be exceeded. Overall length restrictions vary from state to state. In some states it is legal to be more than 12,18 m (40 ft) in length, and some states allow overlength permits.

Specifications

Boom and jib combinations data

Available in three basic models.

Model 851D – Equipped with a 6,4 m - 15,5 m (21 ft - 51 ft) three-section boom. Maximum tip height is 18,9 m (62 ft).



Model 890D – Equipped with a 8,23 m - 27,43 m (27 ft - 90 ft) four-section boom. This model can be equipped with a 7,62 m - 13,41 m (25 ft - 44 ft) two-section jib. Maximum tip height with 13,41 m (44 ft) jib is 43,58 m (143 ft).

8,23 m - 27,43 m (27 ft - 90 ft) four-section boom.



8,23 m - 27,43 m (27 ft - 90 ft) four-section boom.

8FJ44M 7,62 m - 13,41 m (25 ft - 44 ft) two-section jib



Model 8100D – Equipped with a 8,99 m - 30,48 m (29.5 ft - 100 ft) four-section boom. This model can be equipped with a 7,62 m - 13,41 m (25 ft - 44 ft) two-section jib. Maximum tip height with 13,41 m (44 ft) jib is 46,32 m (152 ft).

8,99 m - 30,48 m (29.5 ft - 100 ft) four-section boom.



8,99 m - 30,48 m (29.6 ft - 100 ft) four-section boom.

8FJ44M 7,62 m - 13,41 m (25 ft - 44 ft) two-section jib





Note: Maximum tip is measured with outriggers/stabilizers fully extended.

Specifications

800D winch data

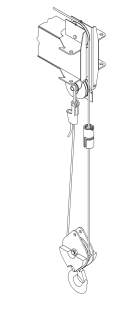
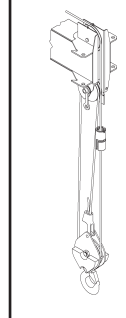
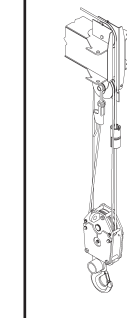
- All winch pulls and speeds in this chart are shown on the **fourth** layer
- Winch line pulls would increase on the first, second and third layers
- Winch line speed would decrease on the first, second and third layers
- Winch line pulls may be limited by the winch capacity or the ANSI 5 to 1 cable safety factor
- Hook blocks are rated at maximum capacity for the block. **Do not exceed rated cable pull with any block.**

1 part line	2 part line	3 part line	4 part line	5 part line	6 part line
					

Winch	Cable supplied	Average breaking strength	Lift and speed	Lift and speed	Lift and speed	Lift and speed	Lift and speed	Lift and speed
Standard planetary winch	9/16" diameter rotation resistant	17 463 kg (38,600 lb)	3492 kg (7700 lb) 45 m/min (147 fpm)	6985 kg (15,400 lb) 22 m/ (73 fpm)	10 477 kg (23,100 lb) 15 m/min (49 fpm)	13 970 kg (30,800 lb) 11 m/min (38 fpm)	17 163 kg (38,500 lb) 9 m/min (29 fpm)	20 865 kg (46,000 lb) 8 m/min (25 fpm)
With "Burst-of-Speed"	9/16" diameter rotation resistant	17 463 kg (38,600 lb)	1360 kg (3000 lb) 62 m/min (206 fpm)	2721 kg (6000 lb) 31 m/min (103 fpm)	4082 kg (9000 lb) 20 m/min (68 fpm)	5443 kg (12,000 lb) 15 m/min (51 fpm)	6803 kg (15,000 lb) 12 m/min (41 fpm)	8164 kg (18,000 lb) 10 m/min (34 fpm)

Winch	Bare drum pull	Allowable cable pull
Standard rotation resistant rope	4627 kg (10,200 lb)	3493 kg (7700 lb)

Loadline deduct		
Block type	Rating	Weight
Downhaul weight	3,49 t (3.85 USt)	68 kg (150 lb)
1-sheave block	10,48 t (11.55 USt)	138 kg (305 lb)
2-sheave block	17,46 t (19,25 USt)	161 kg (355 lb)
3-sheave block	27,21 t (30.00 USt)	261 kg (575 lb)

Capacities

851D: 51 ft boom with no jib

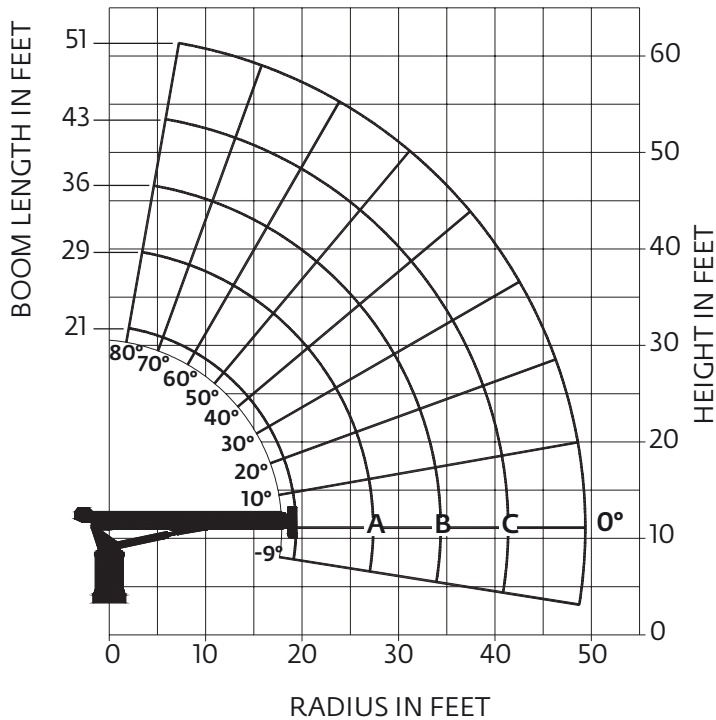

CAUTION:

- Do not operate crane booms, jib extensions, any accessories or loads within 3 m (10 ft) of live power lines or other conductors of electricity.
- Jib and boom capacities shown are maximum for each section.
- Do not exceed capacities at reduced radii.
- Load ratings shown on the load rating charts are maximum allowable loads with the outriggers properly extended on a firm, level surface and the crane leveled and mounted on a factory recommended truck.
- Always level the crane with the level indicator located on the crane.
- The operator must reduce load to allow for factors such as wind, ground conditions, operating speeds and their effects on freely suspended loads.
- Overloading this crane may cause structural collapse or instability.
- Weights on any accessories attached to the boom or loadline must be deducted from the load chart capacities.
- Do not exceed jib capabilities at any reduced boom lengths.
- Do not deadhead lineblock against boom tip when extending boom or winching up.
- Keep at least three wraps of loadline on drum at all times.
- Use only specified cable with this machine.

Load chart

LOAD RADIUS (FEET)	LOADED BOOM ANGLE	21 ft BOOM (lb)	LOADED BOOM ANGLE	A 29 ft BOOM (lb)	LOADED BOOM ANGLE	B 36 ft BOOM (lb)	LOADED BOOM ANGLE	C 43 ft BOOM (lb)	LOADED BOOM ANGLE	51 ft BOOM (lb)
5	73.5	46,000								
8	64	32,800	72	30,500	76	29,000				
10	57.5	27,800	67.5	26,200	72.5	25,100	76	23,800	78	22,500
12	50.5	24,500	63	23,200	69	22,100	73	21,100	76	21,000
14	42.5	21,400	58.5	20,500	65.5	20,000	70	18,800	73.5	18,000
16	33	18,400	53.5	18,300	62	17,500	67	16,600	71	16,500
20			42.5	15,500	54	15,100	61	14,000	66	13,500
25			23	11,400	43	12,500	53	12,000	59.5	11,000
30					29	9300	43.5	10,000	53	9600
35							33	7800	46	8500
40							16	6000	37	6800
45									25	5800
	0	11,200	0	7200	0	5400	0	4200	0	3200

Note: Shaded areas are structurally limited capacities.

THIS CHART IS ONLY A GUIDE AND SHOULD NOT BE USED TO OPERATE THE CRANE.

The individual crane's load chart, operating instructions and other instructional plates must be read and understood prior to operating the crane.

Capacities

890D: 90 ft boom with no jib

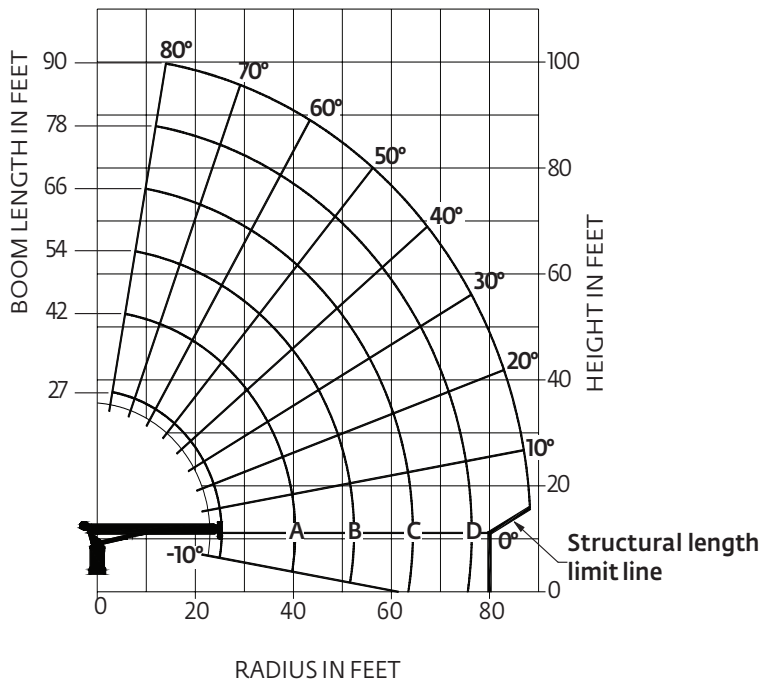

CAUTION:

- Do not operate crane booms, jib extensions, any accessories or loads within 3 m (10 ft) of live power lines or other conductors of electricity.
- Jib and boom capacities shown are maximum for each section.
- Do not exceed capacities at reduced radii.
- Load ratings shown on the load rating charts are maximum allowable loads with the outriggers properly extended on a firm, level surface and the crane leveled and mounted on a factory recommended truck.
- Always level the crane with the level indicator located on the crane.
- The operator must reduce load to allow for factors such as wind, ground conditions, operating speeds and their effects on freely suspended loads.
- Overloading this crane may cause structural collapse or instability.
- Weights on any accessories attached to the boom or loadline must be deducted from the load chart capacities.
- Do not exceed jib capabilities at any reduced boom lengths.
- Do not deadhead lineblock against boom tip when extending boom or winching up.
- Keep at least three wraps of loadline on drum at all times.
- Use only specified cable with this machine.

Load chart

LOAD RADIUS (ft)	LOADED BOOM ANGLE	27 ft BOOM (lb)	LOADED BOOM ANGLE	A 42 ft BOOM (lb)	LOADED BOOM ANGLE	B 54 ft BOOM (lb)	LOADED BOOM ANGLE	C 66 ft BOOM (lb)	LOADED BOOM ANGLE	D 78 ft BOOM (lb)	LOADED BOOM ANGLE	90 ft BOOM (lb)
5	77	46,000										
8	70	33,000										
10	65	27,400	75.5	23,900	79	22,300						
12	60	23,500	72.5	20,900	77	19,100						
14	54.5	20,700	69.5	18,300	75	16,800	78	15,400				
16	49	18,300	66.5	16,300	72.5	14,800	76	13,600	79	12,600		
20	35	14,500	60	13,200	68	12,200	72.5	11,250	76	10,300	78	10,000
25			51.5	10,700	62	9900	68	9150	72	8450	74.5	8100
30			42	8800	55.5	8350	63.5	7450	68	6800	71.5	6500
35			31	7050	49	6900	58	6400	64	5850	68	5550
40					41	5850	53	5500	60	5250	64.5	4750
45					32	4900	47	4750	55	4400	61	4150
50					18.5	3700	40.5	4050	50.5	3850	57	3600
55							32.5	3350	45.5	3300	53	3150
60							22.5	2700	39.5	2900	49	2750
65									33	2450	44	2400
70									25	1950	39	2050
75									12	1150	33.5	1700
80											26.5	1350
85											17	850
	0	7400	0	3500	0	2000	0	950				

Note: Shaded areas are structurally limited capacities.

THIS CHART IS ONLY A GUIDE AND SHOULD NOT BE USED TO OPERATE THE CRANE.

The individual crane's load chart, operating instructions and other instructional plates must be read and understood prior to operating the crane.

Capacities

890D: 90 ft boom with 44 ft jib

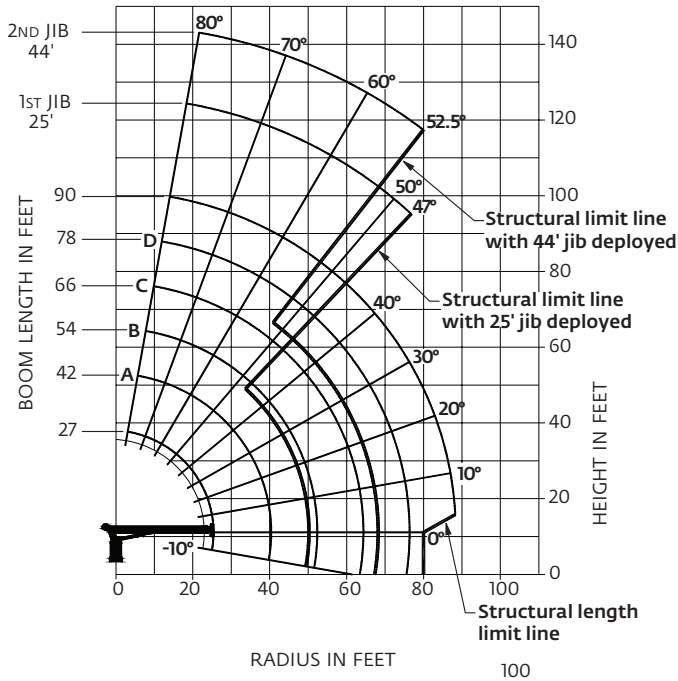

CAUTION:

- Do not operate crane booms, jib extensions, any accessories or loads within 3 m (10 ft) of live power lines or other conductors of electricity.
- Jib and boom capacities shown are maximum for each section.
- Do not exceed capacities at reduced radii.
- Load ratings shown on the load rating charts are maximum allowable loads with the outriggers properly extended on a firm, level surface and the crane leveled and mounted on a factory recommended truck.
- Always level the crane with the level indicator located on the crane.
- The operator must reduce load to allow for factors such as wind, ground conditions, operating speeds and their effects on freely suspended loads.
- Overloading this crane may cause structural collapse or instability.
- Weights on any accessories attached to the boom or loadline must be deducted from the load chart capacities.
- Do not exceed jib capabilities at any reduced boom lengths.
- Do not deadhead lineblock against boom tip when extending boom or winching up.
- Keep at least three wraps of loadline on drum at all times.
- Use only specified cable with this machine.

NOTE:

1. Operate with jib by radius when main boom is fully extended. If necessary increase boom angle to maintain loaded radius.
2. Operate with jib by boom angle when main boom is not fully extended. Do not exceed rated jib capacities at any reduced boom lengths.

Load chart

LOAD RADIUS (ft)	LOADED BOOM ANGLE	27 ft BOOM (lb)	LOADED BOOM ANGLE	A 42 ft BOOM (lb)	LOADED BOOM ANGLE	B 54 ft BOOM (lb)	LOADED BOOM ANGLE	C 66 ft BOOM (lb)	LOADED BOOM ANGLE	D 78 ft BOOM (lb)	LOADED BOOM ANGLE	90 ft BOOM (lb)	LOAD RADIUS (ft)	LOADED BOOM ANGLE	25 ft JIB (lb)	LOADED BOOM ANGLE	44 ft JIB (lb)
5	77	46,000											30	76.5	4800	79	3100
8	70	32,300											35	74	4300	77	2900
10	65	26,700	75.5	23,400	79	21,900							40	71.5	3650	75	2700
12	60	22,800	72.5	20,400	77	18,700							45	68.5	3000	73	2500
14	54.5	19,900	69.5	17,800	75	16,400	78	15,050					50	66	2450	71	2300
16	49	17,500	66.5	15,800	72.5	14,400	76	13,250	79	12,300			55	63	2000	69	2100
20	35	13,700	60	12,700	68	11,800	72.5	10,900	76	10,000	78	9750	60	60	1600	66	1800
25			51.5	10,200	62	9500	68	8800	72	8150	74.5	7850	65	57	1300	63.5	1500
30			42	8300	55.5	7950	63.5	7100	68	6500	71.5	6250	70	54	1000	61	1250
35			31	6550	49	6500	58	6050	64	5550	68	5300	75	50.5	750	58.5	1050
40					41	5450	53	5150	60	4950	64.5	4500	80	47	500	55.5	850
45					32	4500	47	4400	55	4100	61	3900	85			52.5	650
50					18.5	3300	40.5	3700	50.5	3550	57	3350					
55							32.5	3000	45.5	3000	53	2900					
60							22.5	2350	39.5	2600	49	2500					
65									33	2150	44	2150					
70									25	1650	39	1800					
75									12	850	33.5	1450					
80											26.5	1100					
85											17	600					
0		6600	0	3000	0	1600	0	600									
ADD TO CAPACITIES WHEN NO JIB STOWED (lb)		800		500		400		350		300		250					

Note: Shaded areas are structurally limited capacities.

THIS CHART IS ONLY A GUIDE AND SHOULD NOT BE USED TO OPERATE THE CRANE.

The individual crane's load chart, operating instructions and other instructional plates must be read and understood prior to operating the crane.

Capacities

8100D: 100 ft boom with no jib

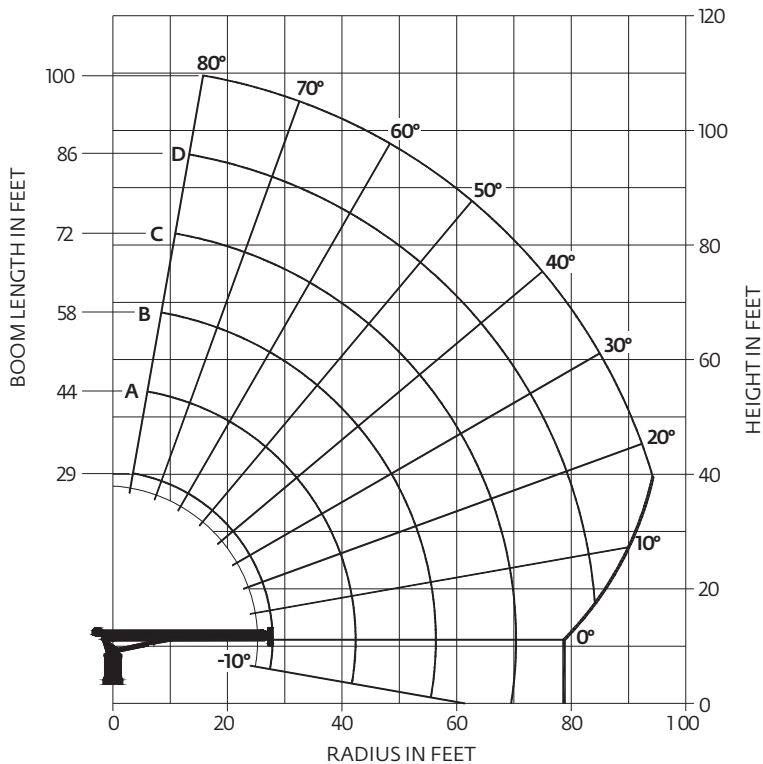

CAUTION:

- Do not operate crane booms, jib extensions, any accessories or loads within 3 m (10 ft) of live power lines or other conductors of electricity.
- Jib and boom capacities shown are maximum for each section.
- Do not exceed capacities at reduced radii.
- Load ratings shown on the load rating charts are maximum allowable loads with the outriggers properly extended on a firm, level surface and the crane leveled and mounted on a factory recommended truck.
- Always level the crane with the level indicator located on the crane.
- The operator must reduce load to allow for factors such as wind, ground conditions, operating speeds and their effects on freely suspended loads.
- Overloading this crane may cause structural collapse or instability.
- Weights on any accessories attached to the boom or loadline must be deducted from the load chart capacities.
- Do not exceed jib capabilities at any reduced boom lengths.
- Do not deadhead lineblock against boom tip when extending boom or winching up.
- Keep at least three wraps of loadline on drum at all times.
- Use only specified cable with this machine.

Load chart

LOAD RADIUS (FEET)	LOADED BOOM ANGLE	29 ft BOOM (lb)	LOADED BOOM ANGLE	A 44 ft BOOM (lb)	LOADED BOOM ANGLE	B 58 ft BOOM (lb)	LOADED BOOM ANGLE	C 72 ft BOOM (lb)	LOADED BOOM ANGLE	D 86 ft BOOM (lb)	LOADED BOOM ANGLE	100 ft BOOM (lb)
5	79	46,000										
8	72.5	31,500	79	28,500								
10	68	26,300	76	23,800								
12	63.5	22,600	73.5	20,300	78	18,500						
14	59	19,800	70.5	17,800	76	16,200	79.5	14,700				
16	54	17,500	68	15,800	74	14,300	77.5	13,000				
20	43	14,200	61	12,800	69.5	11,700	74.5	10,700	77.5	9850		
25	25	10,500	54	10,300	64	9400	70	8600	74	7950	77	7350
30			45	8500	58.5	7800	66	7000	70.5	6450	74	6100
35			35	6900	53	6550	61.5	5950	67	5500	71	5150
40			20	5200	46	5550	56.5	5100	63	4700	67.5	4500
45					38	4700	51.5	4400	59.5	4100	64.5	3900
50					28.5	3850	46	3800	55	3550	61	3400
55					14	2650	40	3250	51	3100	57.5	2900
60							33	2700	46.5	2700	54	2550
65							24	2150	41	2300	50	2100
70							6.5	1050	35.5	1900	46	1900
75									29	1550	42	1600
80									20	1100	37	1300
85											32	1050
90											25	750
	0	5900	0	2900	0	1400	0	500				

Note: Shaded areas are structurally limited capacities.

THIS CHART IS ONLY A GUIDE AND SHOULD NOT BE USED TO OPERATE THE CRANE.

The individual crane's load chart, operating instructions and other instructional plates must be read and understood prior to operating the crane.

Capacities

8100D: 100 ft boom with 44 ft jib

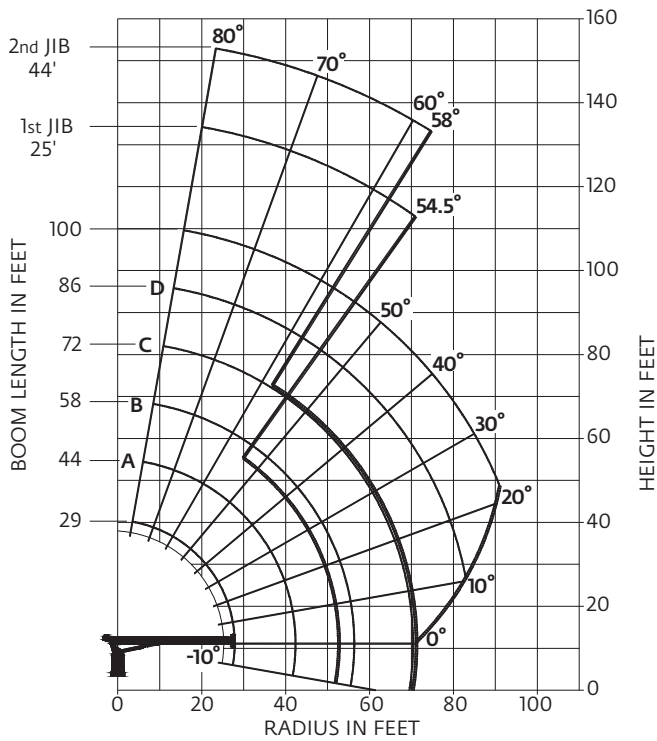

CAUTION:

- Do not operate crane booms, jib extensions, any accessories or loads within 3 m (10 ft) of live power lines or other conductors of electricity.
- Jib and boom capacities shown are maximum for each section.
- Do not exceed capacities at reduced radii.
- Load ratings shown on the load rating charts are maximum allowable loads with the outriggers properly extended on a firm, level surface and the crane leveled and mounted on a factory recommended truck.
- Always level the crane with the level indicator located on the crane.
- The operator must reduce load to allow for factors such as wind, ground conditions, operating speeds and their effects on freely suspended loads.
- Overloading this crane may cause structural collapse or instability.
- Weights on any accessories attached to the boom or loadline must be deducted from the load chart capacities.
- Do not exceed jib capabilities at any reduced boom lengths.
- Do not deadhead lineblock against boom tip when extending boom or winching up.
- Keep at least three wraps of loadline on drum at all times.
- Use only specified cable with this machine.

NOTE:

1. Operate with jib by radius when main boom is fully extended. If necessary increase boom angle to maintain loaded radius.
2. Operate with jib by boom angle when main boom is not fully extended. Do not exceed rated jib capacities at any reduced boom lengths.

Load chart

LOAD RADIUS (FEET)	LOADED BOOM ANGLE	29 ft BOOM (lb)	LOADED BOOM ANGLE	A 44 ft BOOM (lb)	LOADED BOOM ANGLE	B 58 ft BOOM (lb)	LOADED BOOM ANGLE	C 72 ft BOOM (lb)	LOADED BOOM ANGLE	D 86 ft BOOM (lb)	LOADED BOOM ANGLE	100 ft BOOM (lb)	LOAD RADIUS (FEET)	LOADED BOOM ANGLE	25 ft JIB (lb)	LOADED BOOM ANGLE	44 ft JIB (lb)
5	79	46,000											30	78	3900	80	2750
8	72.5	30,700	79	27,900									35	75.5	3400	78	2500
10	68	25,500	76	23,200									40	73	2800	76	2250
12	63.5	21,800	73.5	19,700	78	18,050							45	70.5	2350	74	2000
14	59	19,000	70.5	17,200	76	15,750	79.5	14,350					50	68	1850	72	1850
16	54	16,700	68	15,200	74	13,850	77.5	12,650					55	65	1500	70	1600
20	43	13,400	61	12,200	69.5	11,250	74.5	10,350	77.5	9550	80	7450	60	62.5	1300	67.5	1350
25	25	9700	54	9700	64	8950	70	8250	74	7650	77	7100	65	60	1100	65	1050
30			45	7900	58.5	7350	66	6650	70.5	6150	74	5850	70	57	750	63	950
35			35	6300	53	6100	61.5	5600	67	5200	71	4900	75	54.5	600	60.5	800
40			20	4600	46	5100	56.5	4750	63	4400	67.5	4250	80			58	600
45					38	4250	51.5	4050	59.5	3800	64.5	3650					
50					28.5	3400	46	3450	55	3250	61	3150					
55					14	2200	40	2900	51	2800	57.5	2650					
60							33	2350	46.5	2400	54	2300					
65							24	1800	41	2000	50	1850					
70							6.5	700	35.5	1600	46	1650					
75									29	1250	42	1350					
80									20	800	37	1050					
85											32	800					
90											25	500					
0		5100	0	2300	0	950											

Note: Shaded areas are structurally limited capacities.

THIS CHART IS ONLY A GUIDE AND SHOULD NOT BE USED TO OPERATE THE CRANE.

The individual crane's load chart, operating instructions and other instructional plates must be read and understood prior to operating the crane.

Dimensions

Series	G	Dry weight*	With oil weight*
851D	71 cm (28 in)	6214 kg (13,700 lb)	6448 kg (14,215 lb)
890D	173 cm (68 in)	7468 kg (16,465 lb)	7704 kg (16,985 lb)
8100D	201 cm (79 in)	7797 kg (17,190 lb)	8033 kg (17,710 lb)

*Above weights do not include subbase, reservoir, front or rear stabilizers, jibs, PTO, pump, bed, boom rests, rear bumper, or any other mounting or crane options.

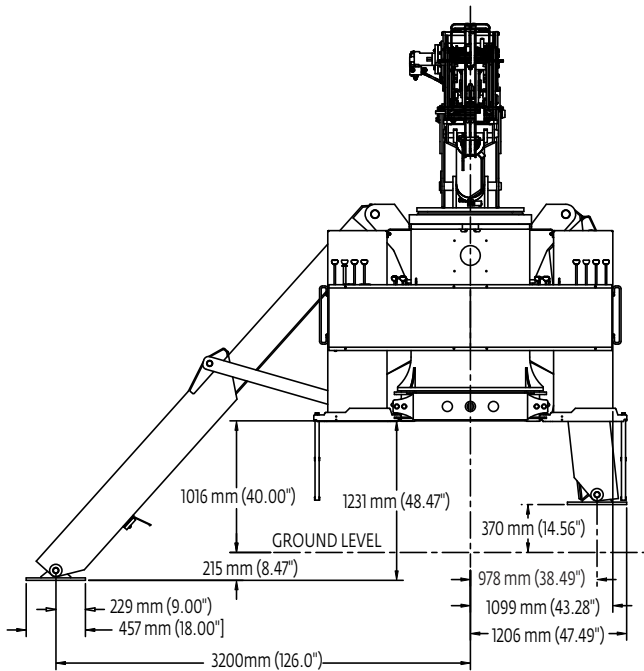

R1115mm (R43.91")
TAILSWING
MAINTAIN CLEARANCE
FOR TAILSWING

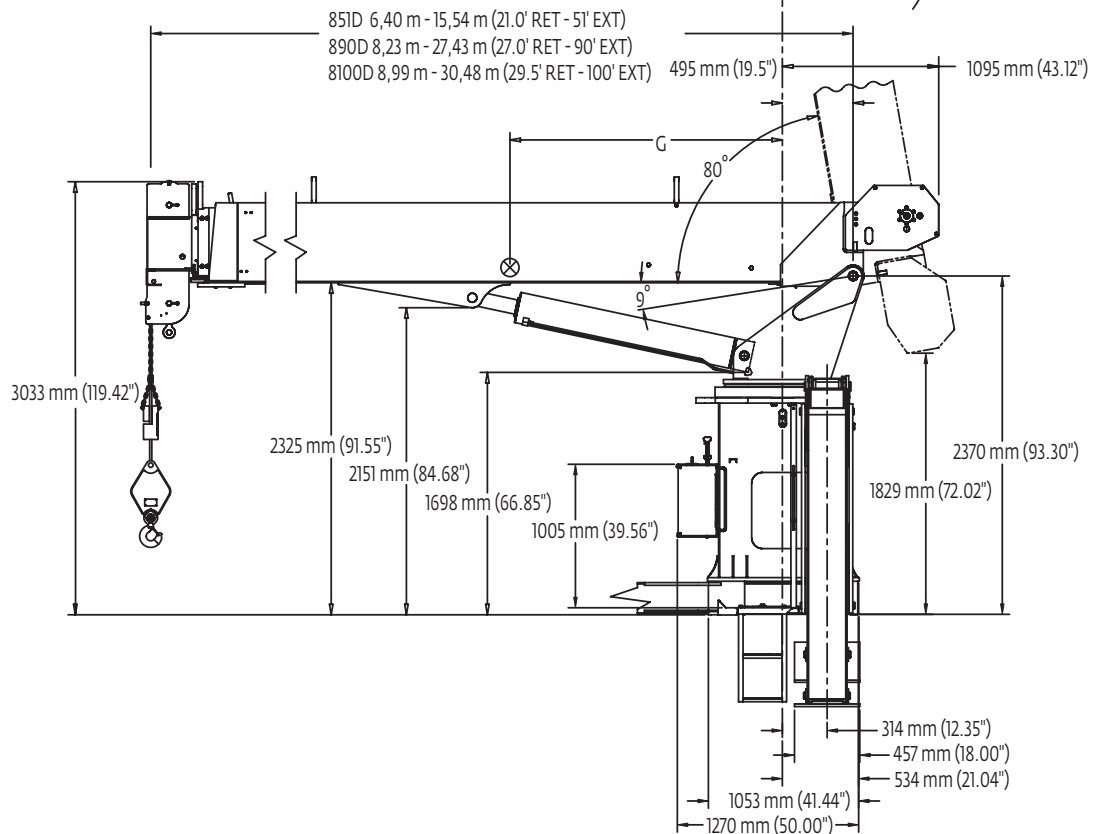
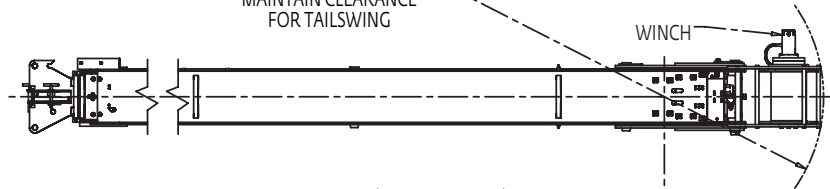

Accessories

Radio Remote Controls –

Eliminate the handling and maintenance concerns that accompany cabled remotes. Operate to a range of about 76 m (250 ft), varying with conditions.

- NB4R

Heavy-duty Personnel Basket –

One and two person baskets for main boom and jib are available.

- BSA-1
- BSA-R1 (provides rotation)
- BSAY-1
- BSAY-2

Hydraulic Oil Cooler –

Automatic, self-contained radiator system with electric fans cools oil under continuous operation.

- OC

Single Front Outrigger –

Center mount front stabilizer for 360° stability with 25 inch vertical stroke.

- SFO

Bulkhead Options –

Steel 30 in solid wall bulkhead.

- BHSD

Spanish-Language Danger Decals, Control Knobs, and Operators' Manuals –

- SDD
- SOM

Manitowoc Cranes

Regional headquarters

Americas

Manitowoc, Wisconsin, USA

Tel: +1 920 684 6621

Fax: +1 920 683 6277

Shady Grove, Pennsylvania, USA

Tel: +1 717 597 8121

Fax: +1 717 597 4062

Europe, Middle East, Africa

Ecully, France

Tel: +33 (0)4 72 18 20 20

Fax: +33 (0)4 72 18 20 00

China

Shanghai, China

Tel: +86 21 6457 0066

Fax: +86 21 6457 4955

Greater Asia-Pacific

Singapore

Tel: +65 6264 1188

Fax: +65 6862 4040

Regional offices

Americas

Brazil

Alphaville

Mexico

Monterrey

Chile

Santiago

Europe, Middle East,

Africa

Czech Republic

Netvorice

France

Baudemont

Cergy

Decines

Germany

Langenfeld

Hungary

Budapest

Italy

Lainate

Netherlands

Breda

Poland

Warsaw

Portugal

Baltar

Russia

Moscow

U.A.E.

Dubai

U.K.

Buckingham

China

Beijing

Chengdu

Guangzhou

Xian

Greater Asia-Pacific

Australia

Adelaide

Brisbane

Melbourne

Sydney

India

Calcutta

Chennai

Delhi

Hyderabad

Pune

Korea

Seoul

Philippines

Makati City

Singapore

Factories

Brazil

Alphaville

China

TaiAn

Zhangjiagang

France

Charlieu

Moulins

Germany

Wilhelmshaven

India

Pune

Italy

Niella Tanaro

Portugal

Baltar

Fânzeres

Slovakia

Saris

USA

Manitowoc

Port Washington

Shady Grove

This document is non-contractual. Constant improvement and engineering progress make it necessary that we reserve the right to make specification, equipment, and price changes without notice. Illustrations shown may include optional equipment and accessories and may not include all standard equipment.