

National Crane Series 900A

Product Guide



Features

- 23,6 t (26 USt) rating
- 31,4 m (103 ft) four-section boom
- Self-lubricating Easy Glide wear pads
- Internal anti-two block



Features

Boom

The 31,4 m (103 ft) four-section boom allows the operator to perform more lifts without the use of a jib, reducing setup time and improving efficiency.



Outriggers

"A" frame main outriggers with 21 ft span. RSOD 16 ft out and down, rear stabilizers for standard behind-cab mount.

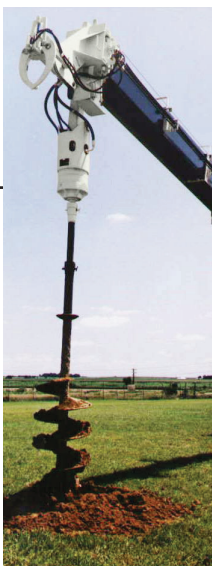

Two-speed auger option

Available on the 990A, the 14,000 ft/lb two-speed drive auger with a maximum digging radius of 39 ft gives your crane enhanced working capabilities. Controls are located at the operator's console and hose slider on boom. Auger fighting is available.

Easy Glide boom wear pads

Reduce the conditions that cause boom chatter and vibration resulting in smoother crane operation.



Features



* Product may be shown with optional equipment.

Performance you can rely on

- The Series 900A is standard with 375° non-continuous rotation.
- Burst of speed winch provides faster winch payout and pickup of unloaded cable.
- The stronger standard torsion box improves rigidity, reduces truck frame flex and reduces the need for counterweight.
- A control knob located on the swing motor brake release valve can be easily adjusted to the crane operator's swing speed preference.
- Bearings on the boom and retract cables can be greased through access holes in the boom side plates.
- Number of internal boom parts has been reduced, decreasing service time when rebuilding the machine.
- Standard on the 900A, internal anti-two block wire routing eliminates the external reel and wire, removing the possibility of snagging reel or wire on obstructions and causing damage.
- Painting crane components before assembly reduces the possibility of rust, improves serviceability and enhances the appearance of the machine.
- A removable winch allows the internal telescoping cylinder to be removed quickly, without dismantling the boom.
- Speedy-reeve boom tip and sheave blocks simplify rigging changes by decreasing the time needed to change line reeving.

Contents

Mounting configurations	5
Specifications	6
Capacities	8
Dimensions	12
Accessories	13

Mounting configurations

The configurations are based on the Series 900A with an 85% stability factor. The complete unit must be installed in accordance with factory requirements and a test performed to determine actual stability and counterweight requirements since individual truck chassis vary.

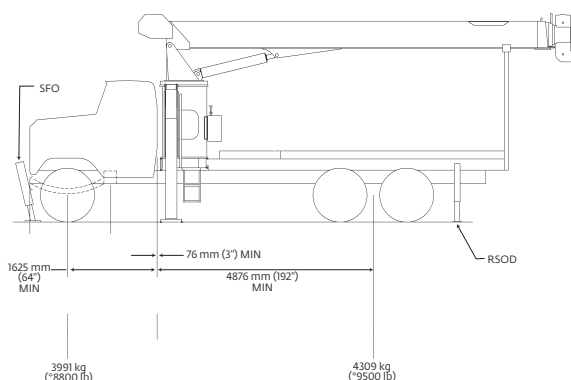

Configuration 1 – 9103A with SFO (Extended front frame rails required for SFO installation.)

Working area	360°
Gross Axle Weight Rating Front.....	7257 kg (16,000 lb)
Gross Axle Weight Rating Rear.....	15 422 kg (34,000 lb)
Gross Vehicle Weight Rating.....	22 679 kg (50,000 lb)
Wheelbase.....	650 cm (256 in)
Cab to Axle/trunnion (CA/CT)	488 cm (192 in)
Frame Section Modulus (SM) under crane: 758 MPa (110,000 PSI)	327 cm ³ (20 in ³)
Frame Section Modulus (SM) over rear stabilizers: 758 MPa (110,000 PSI)	245 cm ³ (15 in ³)
Stability Weight, Front	3991 kg (8800 lb) minimum*
Stability Weight, Rear	4309 kg (9500 lb) minimum*
Estimated Average Final Weight	19 459 kg (42,900 lb)

This mount requires front stabilizer for full capacity 360° around the truck. Front stabilizer gives the machine a solid base, helping the operator control loads. This configuration requires a 6,71 m (22 ft) bed.

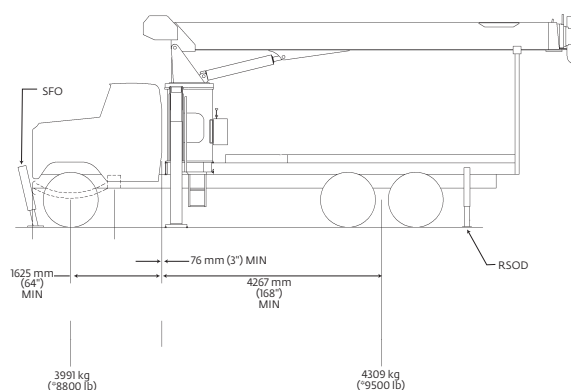

Configuration 2 – 990A with SFO (Extended front frame rails required for SFO installation.)

Working area	360°
Gross Axle Weight Rating Front.....	7257 kg (16,000 lb)
Gross Axle Weight Rating Rear.....	15 422 kg (34,000 lb)
Gross Vehicle Weight Rating.....	22 679 kg (50,000 lb)
Wheelbase.....	589 cm (232 in)
Cab to Axle/trunnion (CA/CT)	427 cm (168 in)
Frame Section Modulus (SM) under crane: 758 MPa (110,000 PSI)	327 cm ³ (20 in ³)
Frame Section Modulus (SM) over rear stabilizers: 758 MPa (110,000 PSI)	245 cm ³ (15 in ³)
Stability Weight, Front	3991 kg (8800 lb) minimum*
Stability Weight, Rear	4309 kg (9500 lb) minimum*
Estimated Average Final Weight	18 551 kg (40,900 lb)

This configuration allows the installation of the 990A on a chassis by using a subbase for a 6,10 m (20 ft) bed or a different subbase for a 6,71 m (22 ft) bed. This mount requires front stabilizer for full capacity 360° around the truck. Front stabilizer gives the machine a solid base, helping the operator control loads.

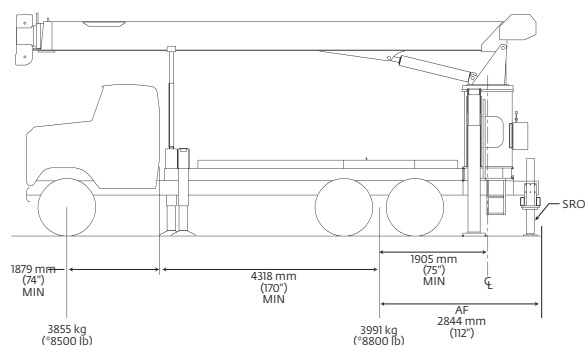

Configuration 3 – Rear Mount

Working area	360°
Gross Axle Weight Rating Front.....	7257 kg (16,000 lb)
Gross Axle Weight Rating Rear.....	18 143 kg (40,000 lb)
Gross Vehicle Weight Rating.....	25 401 kg (56,000 lb)
Wheelbase.....	620 cm (244 in)
Cab to Axle/trunnion (CA/CT)	MINIMUM 432 cm (170 in)
Frame Section Modulus (SM) under crane: 758 MPa (110,000 PSI)	260 cm ³ (15.9 in ³)
Stability Weight, Front	3855 kg (8500 lb) minimum*
Stability Weight, Rear	3991 kg (7000 lb) minimum*
Estimated Average Final Weight	19 504 kg (43,000 lb)

This configuration allows the rear-mount installation of the Series 900A. This configuration is 360° stable and allows the effective use of close working area to lift the heavier capacity loads. Maximum bed length is 4,87 m (16 ft).

Notes:

- Gross Vehicle Weight Rating (GVWR) is dependent on all components of the vehicle (axles, tires, springs, frame, etc.) meeting manufacturers' recommendations; always specify GVWR when purchasing trucks
- Diesel engines require a variable speed governor and energize-to-run fuel solenoid for smooth crane operation; electronic fuel injection requires EET engine remote throttle

- All mounting data is based on a National Series 900A with an 85 percent stability factor
- The complete unit must be installed in accordance with factory requirements, and a test performed to determine actual stability and counterweight requirements per SAE J765; contact the factory for details
- Transmission neutral safety interlock switch is required with optional remote control

*Estimated axle scale rates prior to installation of crane, stabilizers and subbase for 85% stability.

Specifications

Boom and jib combinations data

Model 990A – Equipped with a 8,38 m - 27,4 m (27 ft 6 in - 90 ft 6 in) four-section boom. This model can be equipped with a 7,62 m - 13,41 m (25 ft - 44 ft) two-section jib. Maximum tip height with 13,41 m (44 ft) jib is 43,58 m (143 ft).

8,38 m - 27,58 m (27 ft 6 in - 90 ft 6 in) four-section boom **9FJ44M** 7,62 m - 13,41 m (25 ft - 44 ft) two-section jib



Model 9103A – Equipped with a 9,37 m - 31,4 m (30 ft 9 in - 102 ft 10 in) four-section boom. This model can be equipped with a 7,62 m - 13,41 m (25 ft - 44 ft) two-section jib. Maximum tip height with 13,41 m (44 ft) jib is 47,24 m (155 ft).

9,37 m - 31,34 m (30 ft 9 in - 102 ft 10 in) four-section boom **9FJ44M** 7,62 m - 13,41 m (25 ft - 44 ft) two-section jib









Note: Maximum tip height is measured with outriggers/stabilizers fully extended.

Specifications

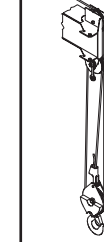
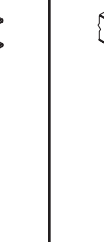
900A winch data

- All winch pulls and speeds in this chart are shown on the fourth layer
- Winch line pulls would increase on the first, second and third layers
- Winch line speed would decrease on the first, second and third layers
- Winch line pulls may be limited by the winch capacity or the ANSI 5 to 1 cable safety factor
- Hook blocks are rated at maximum capacity for the block. Do not exceed rated cable pull with any block.

1 part line	2 part line	3 part line	4 part line	5 part line	6 part line	7 part line
						
MAX. PULL 7700 lb	MAX. PULL 15,400 lb	MAX. PULL 23,100 lb	MAX. PULL 30,800 lb	MAX. PULL 38,500 lb	MAX. PULL 46,200 lb	MAX. PULL 52,000 lb

Winch	Cable supplied	Avg. breaking strength	Lift and speed	Lift and speed	Lift and speed	Lift and speed	Lift and speed	Lift and speed	Lift and speed
Standard planetary winch	9/16 in diameter rotation resistant	17 463 kg (38,500 lb)	3492 kg (7700 lb)	6985 kg (15,400 lb)	10 477 kg (23,100 lb)	13 970 kg (30,800 lb)	17 463 kg (38,500 lb)	20 955 kg (46,200 lb)	23 586 kg (52,000 lb)
			41 m/min (135 fpm)	20 m/min (68 fpm)	13 m/min (45 fpm)	10 m/min (34 fpm)	8 m/min (27 fpm)	7 m/min (23 fpm)	5 m/min (19 fpm)
With "Burst of Speed" winch	Same as corresponding cable data shown above		1360 kg (3000 lb)	2721 kg (6000 lb)	4082 kg (9000 lb)	5443 kg (12,000 lb)	6803 kg (15,000 lb)	8164 kg (18,000 lb)	9525 kg (21,000 lb)
			62 m/min (206 fpm)	31 m/min (103 fpm)	19,51 m/min (64 fpm)	15 m/min (51 fpm)	12 m/min (41 fpm)	10 m/min (34 fpm)	8 m/min (29 fpm)

Winch	Bare drum pull	Allowable cable pull
With standard rotation resistant rope	4627 kg (10,200 lb)	3493 kg (7700 lb)

Block Type	Rating	Weight
Downhaul Weight	3,49 t (3.85 USt)	68 kg (150 lb)
1 Sheave Block	10,48 t (11.55 USt)	138 kg (305 lb)
2 Sheave Block	17,46 t (19.25 USt)	161 kg (355 lb)
3 Sheave Block	27,22 t (30 USt)	260 kg (575 lb)

THIS CHART IS ONLY A GUIDE AND SHOULD NOT BE USED TO OPERATE THE CRANE.

The individual crane's load chart, operating instructions and other instructional plates must be read and understood prior to operating the crane.

Capacities

Series 990A: 90 ft boom (with LMI)

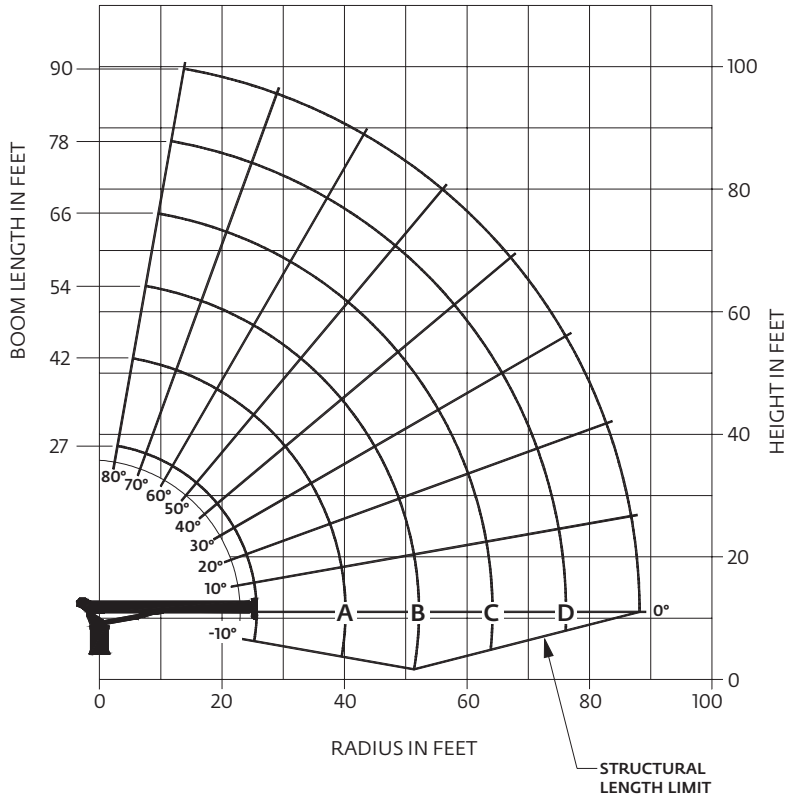

CAUTION:

- Do not operate crane booms, jib extensions, any accessories or loads within 3 m (10 ft) of live power lines or other conductors of electricity.
- Jib and boom capacities shown are maximum for each section.
- Do not exceed capacities at reduced radii
- Load ratings shown on the load rating charts are maximum allowable loads with the outriggers properly extended on a firm, level surface and the crane leveled and mounted on a factory recommended truck.
- Always level the crane with the level indicator located on the crane.
- The operator must reduce load to allow for factors such as wind, ground conditions, operating speeds and their effects on freely suspended loads.
- Overloading this crane may cause structural collapse or instability.
- Weights on any accessories attached to the boom or loadline must be deducted from the load chart capacities.
- Do not deadhead lineblock against boom tip when extending boom or winching up.
- Keep at least three wraps of loadline on drum at all times.
- Use only specified cable with this machine.

Load chart

LOAD RADIUS (FEET)	LOADED BOOM ANGLE	27 ft BOOM (lb)	LOADED BOOM ANGLE	A 42 ft BOOM (lb)	LOADED BOOM ANGLE	B 54 ft BOOM (lb)	LOADED BOOM ANGLE	C 66 ft BOOM (lb)	LOADED BOOM ANGLE	D 78 ft BOOM (lb)	LOADED BOOM ANGLE	90 ft BOOM (lb)
5	77	52,000										
8	70.5	36,600										
10	66	31,300	75	27,300	79	25,600						
12	60.5	26,600	72	23,400	77	21,900						
14	55.5	22,300	69	20,500	74	20,400	78	18,300				
16	50	20,000	66	18,200	72.5	17,000	76	15,900	78.5	14,900		
20	38.5	15,500	59.5	15,000	67.5	14,800	72.5	13,800	75.5	12,700	78	11,600
25			51.5	11,700	61.5	11,300	68	11,200	71.5	10,500	74.5	9400
30			41.5	9450	55	9200	62.5	9200	67.5	8800	71	7900
35			30	7450	48.5	7650	58	7400	64	7350	68	6800
40					41	6400	52.5	6200	59.5	6050	64.5	5950
45					31.5	5200	46.5	5300	55	5100	61	5000
50					17.5	4150	40	4550	50.5	4450	57	4350
55							32.5	3750	45	3850	53	3800
60							22	2850	39.5	3300	48.5	3350
65									33	2750	44	2900
70									24.5	2150	39	2450
75									11	1250	33.5	2050
80											26.5	1650
85											16.5	1050
	0	7100	0	3400	0	1900	0	900				

Note:

1. Capacities do not exceed 85% stability.
2. Shaded areas are structurally limited capacities.

THIS CHART IS ONLY A GUIDE AND SHOULD NOT BE USED TO OPERATE THE CRANE.

The individual crane's load chart, operating instructions and other instructional plates must be read and understood prior to operating the crane.

Capacities

Series 990A: 90 ft boom with 44 ft jib

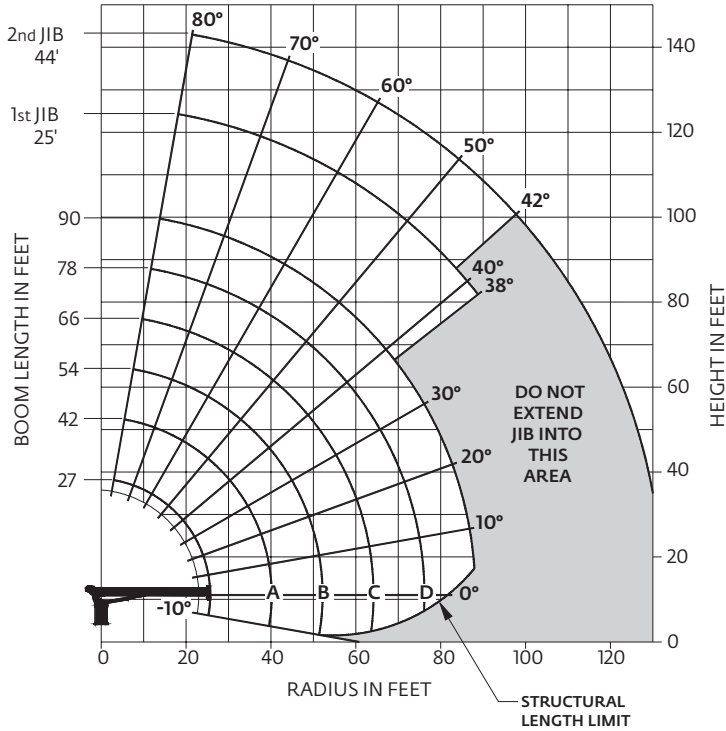

CAUTION:

- Do not operate crane booms, jib extensions, any accessories or loads within 3 m (10 ft) of live power lines or other conductors of electricity.
- Jib and boom capacities shown are maximum for each section.
- Do not exceed capacities at reduced radii
- Load ratings shown on the load rating charts are maximum allowable loads with the outriggers properly extended on a firm, level surface and the crane leveled and mounted on a factory recommended truck.
- Always level the crane with the level indicator located on the crane.
- The operator must reduce load to allow for factors such as wind, ground conditions, operating speeds and their effects on freely suspended loads.
- Overloading this crane may cause structural collapse or instability.
- Weights on any accessories attached to the boom or loadline must be deducted from the load chart capacities.
- Do not exceed jib capacities at any reduced boom lengths.
- Do not deadhead lineblock against boom tip when extending boom or winching up.
- Keep at least three wraps of loadline on drum at all times.
- Use only specified cable with this machine.

Note:

1. Operate with jib by radius when main boom is fully extended. If necessary increase boom angle to maintain loaded radius.
2. Operate with jib by boom angle when main boom is not fully extended. Do not exceed rated jib capacities at any reduced boom lengths.

Load chart

LOAD RADIUS (FEET)	LOADED BOOM ANGLE	27 ft BOOM (lb)	LOADED BOOM ANGLE	A 42 ft BOOM (lb)	LOADED BOOM ANGLE	B 54 ft BOOM (lb)	LOADED BOOM ANGLE	C 66 ft BOOM (lb)	LOADED BOOM ANGLE	D 78 ft BOOM (lb)	LOADED BOOM ANGLE	90 ft BOOM (lb)	LOAD RADIUS (FEET)	LOADED BOOM ANGLE	25 ft JIB (lb)	LOADED BOOM ANGLE	44 ft JIB (lb)
5	77	52,000											30	75	4850	77.5	3300
8	70.5	35,900											35	72.5	4350	75	3250
10	66	30,600	75	26,900	79	25,300							40	70	3900	73	3200
12	60.5	25,900	72	23,000	77	21,600							45	67	3500	71	3050
14	55.5	21,600	69	20,100	74	20,100	78	18,100					50	64.5	3150	69	2750
16	50	19,300	66	17,800	72.5	16,700	76	15,700	78.5	14,700			55	61.5	2800	66.5	2400
20	38.5	14,800	59.5	14,600	67.5	14,500	72.5	13,600	75.5	12,500	78	11,500	60	59	2500	64	2150
25			51.5	11,300	61.5	11,000	68	11,000	71.5	10,300	74.5	9300	65	56	2200	61.5	1900
30			41.5	9050	55	8900	62.5	9000	67.5	8600	71	7800	70	52.5	1750	59	1700
35			30	7050	48.5	7350	58	7200	64	7150	68	6700	75	49	1400	56.5	1550
40					41	6100	52.5	6000	59.5	5850	64.5	5850	80	45.5	1100	54	1400
45					31.5	4900	46.5	5100	55	4900	61	4900	85	42	800	51.5	1250
50					17.5	3850	40	4350	50.5	4250	57	4250	90	38	550	48	1000
55							32.5	3550	45	3650	53	3700	95			45	800
60							22	2650	39.5	3100	48.5	3250	100			42	600
65									33	2550	44	2800					
70									24.5	1950	39	2350					
75									11	1050	33.5	1950					
80											26.5	1550					
85											16.5	950					
	0	6400	0	3000	0	1600	0	700									
	ADD TO CAPACITIES WHEN NO JIB STOWED (lb)	700		400		300		200		200		100					

Note:

1. Capacities do not exceed 85% stability.
2. Shaded areas are structurally limited capacities.

Capacities

Series 9103A: 103 ft boom (with LMI)

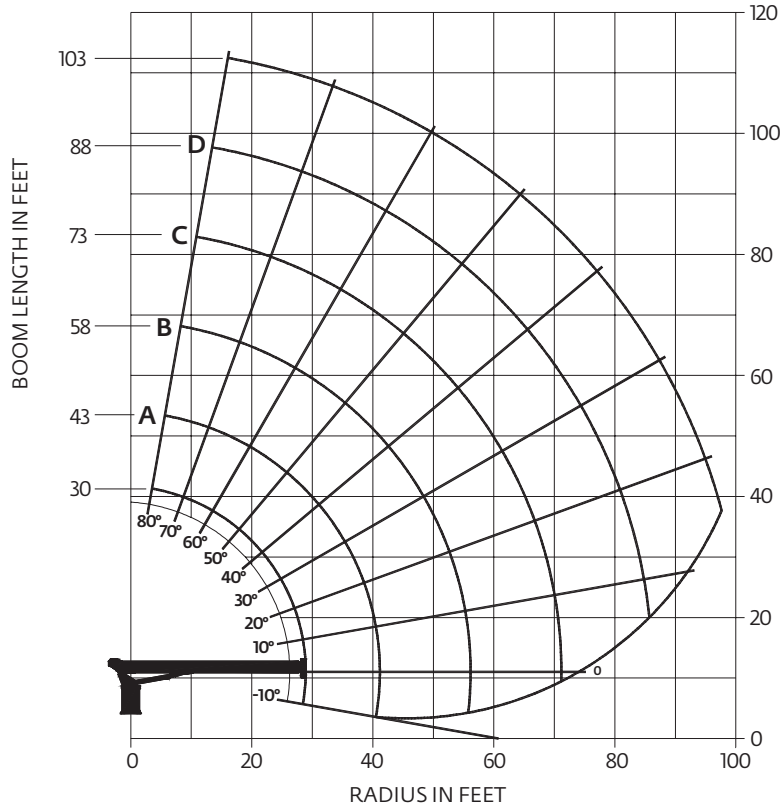

CAUTION:

- Do not operate crane booms, jib extensions, any accessories or loads within 3 m (10 ft) of live power lines or other conductors of electricity.
- Jib and boom capacities shown are maximum for each section.
- Do not exceed capacities at reduced radii
- Load ratings shown on the load rating charts are maximum allowable loads with the outriggers properly extended on a firm, level surface and the crane leveled and mounted on a factory recommended truck.
- Always level the crane with the level indicator located on the crane.
- The operator must reduce load to allow for factors such as wind, ground conditions, operating speeds and their effects on freely suspended loads.
- Overloading this crane may cause structural collapse or instability.
- Weights on any accessories attached to the boom or loadline must be deducted from the load chart capacities.
- Do not deadhead lineblock against boom tip when extending boom or winching up.
- Keep at least three wraps of loadline on drum at all times.
- Use only specified cable with this machine.

Load chart

LOAD RADIUS (FEET)	LOADED BOOM ANGLE	30 ft BOOM (lb)	LOADED BOOM ANGLE	A 43 ft BOOM (lb)	LOADED BOOM ANGLE	B 58 ft BOOM (lb)	LOADED BOOM ANGLE	C 73 ft BOOM (lb)	LOADED BOOM ANGLE	D 88 ft BOOM (lb)	LOADED BOOM ANGLE	103 ft BOOM (lb)
5	78.5	52,000										
8	72.5	35,700										
10	68.5	29,900	75.5	27,000	80	25,400						
12	64.5	25,600	72.5	23,100	78	21,700						
14	60	22,100	69.5	20,200	76	19,800	79.5	18,100				
16	55.5	19,800	67	17,900	74	16,800	78	15,700	80	14,600		
20	45	15,200	60.5	14,600	69	14,200	74	13,000	77.5	12,000	80	10,800
25			52	11,400	63.5	11,000	70	10,500	74	9700	77	9350
30			42.5	9100	57.5	8950	65.5	8700	70.5	8050	74.5	7400
35			32.5	7100	52.5	7350	62	7150	67.5	6700	71.5	6300
40					45.5	6100	57	5950	64	5750	68.5	5400
45					38	4950	52	5050	60	4900	65.5	4750
50					28	3900	46.5	4300	56	4250	62	4150
55							40.5	3500	52	3600	59	3600
60							34	2900	47.5	3050	55.5	3150
65									42.5	2500	52	2700
70									37.5	2050	48	2300
75									31	1650	44	1900
80											39.5	1500
85											34.5	1150
	0	5350	0	2800	0	1250						

Note:

1. Capacities do not exceed 85% stability.
2. Shaded areas are structurally limited capacities.

THIS CHART IS ONLY A GUIDE AND SHOULD NOT BE USED TO OPERATE THE CRANE.

The individual crane's load chart, operating instructions and other instructional plates must be read and understood prior to operating the crane.

Capacities

Series 9103A: 103 ft boom with 14 ft jib

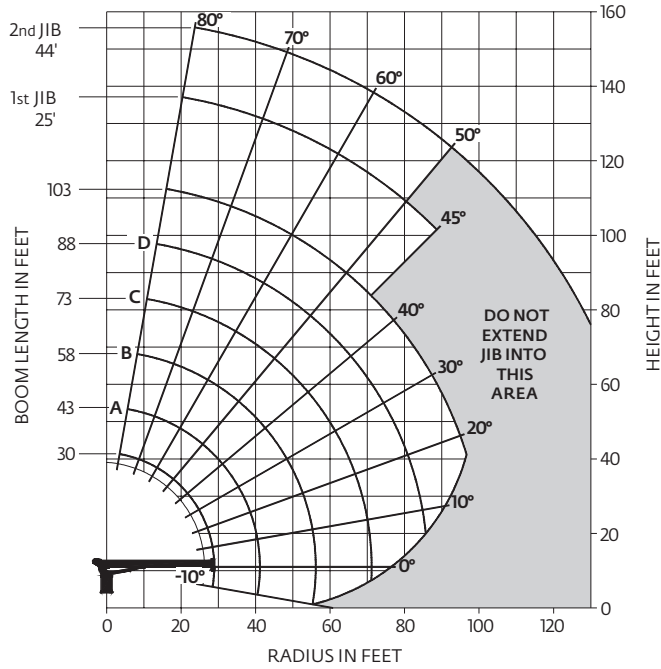

Note:

1. Operate with jib by radius when main boom is fully extended. If necessary increase boom angle to maintain loaded radius.
 2. Operate with jib by boom angle when main boom is not fully extended.
- Do not exceed rated jib capacities at any reduced boom lengths.

CAUTION:

- Do not operate crane booms, jib extensions, any accessories or loads within 3 m (10 ft) of live power lines or other conductors of electricity.
- Jib and boom capacities shown are maximum for each section.
- Do not exceed capacities at reduced radii
- Load ratings shown on the load rating charts are maximum allowable loads with the outriggers properly extended on a firm, level surface and the crane leveled and mounted on a factory recommended truck.
- Always level the crane with the level indicator located on the crane.
- The operator must reduce load to allow for factors such as wind, ground conditions, operating speeds and their effects on freely suspended loads.
- Overloading this crane may cause structural collapse or instability.
- Weights on any accessories attached to the boom or loadline must be deducted from the load chart capacities.
- Do not exceed jib capabilities at any reduced boom lengths.
- Do not deadhead lineblock against boom tip when extending boom or winching up.
- Keep at least three wraps of loadline on drum at all times.
- Use only specified cable with this machine.

Load chart

LOAD RADIUS (FEET)	LOADED BOOM ANGLE	30 ft BOOM (lb)	LOADED BOOM ANGLE	A 43 ft BOOM (lb)	LOADED BOOM ANGLE	B 58 ft BOOM (lb)	LOADED BOOM ANGLE	C 73 ft BOOM (lb)	LOADED BOOM ANGLE	D 88 ft BOOM (lb)	LOADED BOOM ANGLE	103 ft BOOM (lb)	LOAD RADIUS (FEET)	LOADED BOOM ANGLE	25 ft JIB (lb)	LOADED BOOM ANGLE	44 ft JIB (lb)
5	78.5	52,000											30	76.5	3950		
8	72.5	34,850											35	74.5	3450	76.5	2550
10	68.5	29,050	75.5	26,400	80	24,950							40	72	3050	75	2500
12	64.5	24,750	72.5	22,500	78	21,250							45	70	2600	73	2450
14	60	21,250	69.5	19,600	76	19,350	79.5	17,750					50	67.5	2250	71	2250
16	55.5	18,950	67	17,300	74	16,350	78	15,350	80	14,300			55	65	1950	69	1850
20	45	14,350	60.5	14,000	69	13,750	74	12,650	77.5	11,700	80	10,550	60	62.5	1800	67	1650
25			52	10,800	63.5	10,550	70	10,150	74	9400	77	9100	65	60	1550	64.5	1350
30			42.5	8500	57.5	8500	65.5	8350	70.5	7750	74.5	7150	70	57.5	1300	62.5	1200
35			32.5	6500	52.5	6900	62	6800	67.5	6400	71.5	6050	75	54.5	1100	60	1050
40					45.5	5650	57	5600	64	5450	68.5	5150	80	51.5	900	58	950
45					38	4500	52	4700	60	4600	65.5	4500	85	48.5	700	55.5	900
50					28	3450	46.5	3950	56	3950	62	3900	90	45.5	450	53	750
55							40.5	3150	52	3300	59	3350	95			50.5	600
60							34	2550	47.5	2750	55.5	2900					
65									42.5	2200	52	2450					
70									37.5	1750	48	2050					
75									31	1350	44	1650					
80											39.5	1250					
85											34.5	900					
	0	4500	0	2200	0	800											
	ADD TO CAPACITIES WHEN NO JIB STOWED (lb)	850		600		450		350		300		250					

Note:

1. Capacities do not exceed 85% stability.
2. Shaded areas are structurally limited capacities.

Dimensions

Series	Retracted length	Extended length	G	Dry weight *	w/oil weight*
*990A	27 ft 6 in	90 ft 6 in	238 cm (94 in)	9536 kg (21,025 lb)	9802 kg (21,610 lb)
**9103A	30 ft 9 in	102 ft 10 in	269 cm (106 in)	10 047 kg (22,150 lb)	10 312 kg (22,735 lb)

* Includes standard 20 ft subbase

** Includes standard 22 ft subbase

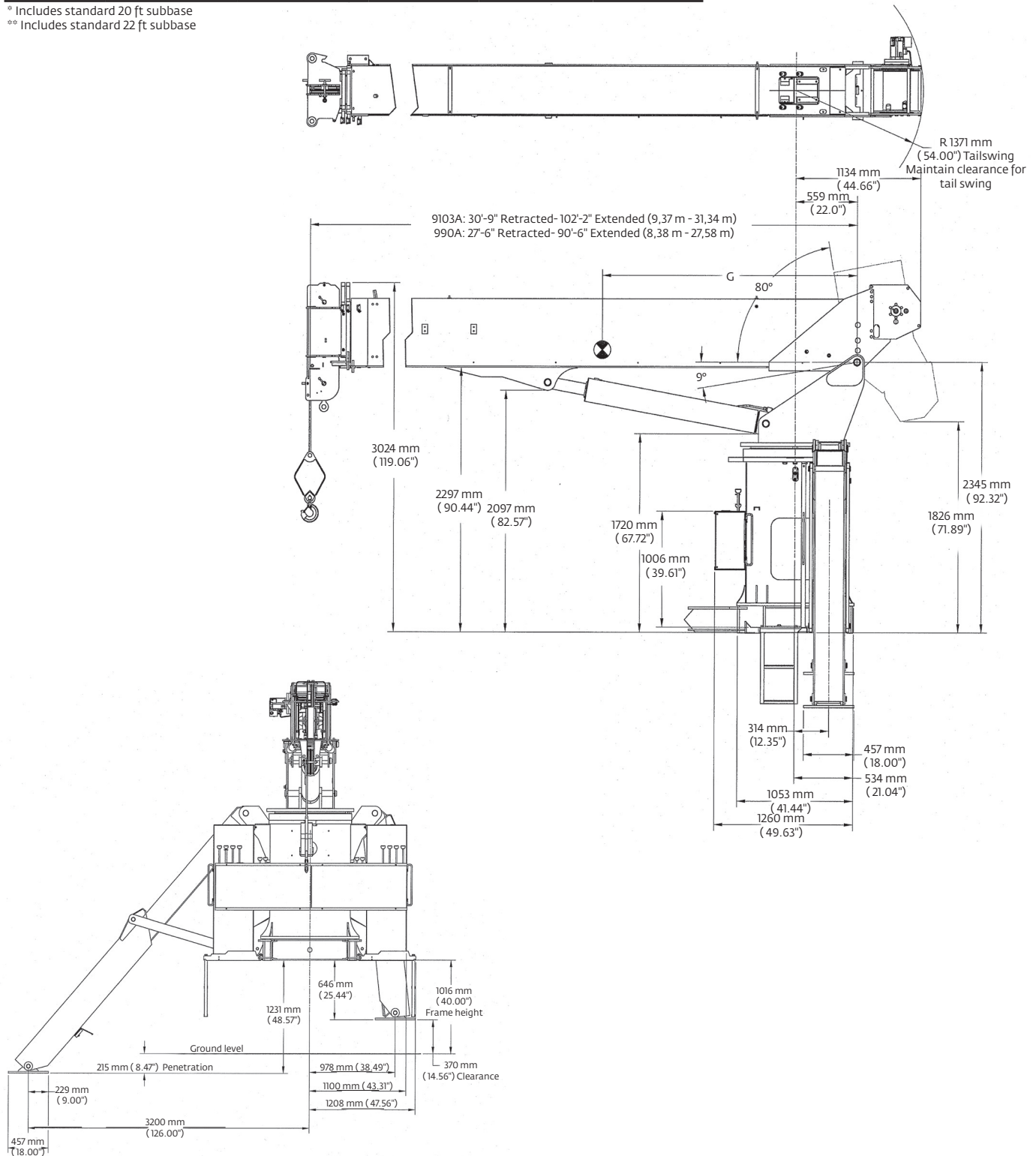

Accessories

Radio Remote Controls –

Eliminate the handling and maintenance concerns that accompany cabled remotes. Operate to a range of about 76 m (250 ft), varying with conditions.

Heavy-duty Personnel Basket –

544 kg (1200 lb) capacity steel basket with safety loops for two passengers. Gravity leveling 183 cm x 107 cm (72 in x 42 in) platform. Fast attachment and secure locking systems. Load chart must show 1043 kg (2300 lb) minimum to operate this accessory.

Hydraulic Oil Cooler –

Automatic, self-contained radiator system with electric fans cools oil under continuous operation.

Single Front Outrigger –

Center front stabilizer with a 25 in vertical stroke

Spanish-Language Danger Decals, Control Knobs, and Operators' Manuals

- **RB4R (R4 functions)**

- **BSA-1**
- **BSA-R1 (provides rotation)**
- **BSAY-1**
- **BSAY-2**

- **OC**

- **SFO**

- **SDD**
- **SOM**



Notes

Notes

Regional headquarters

Manitowoc - Americas

Manitowoc, Wisconsin, USA

Tel: +1 920 684 6621

Fax: +1 920 683 6277

Shady Grove, Pennsylvania, USA

Tel: +1 717 597 8121

Fax: +1 717 597 4062

Manitowoc - Europe, Middle East, Africa

Ecully, France

Tel: +33 (0)4 72 18 20 20

Fax: +33 (0)4 72 18 20 00

Manitowoc - Asia Pacific

Shanghai, China

Tel: +86 21 6457 0066

Fax: +86 21 6457 4955

Regional offices

Americas

Brazil

Alphaville

Mexico

Monterrey

Chile

Santiago

Europe, Middle East, Africa

Czech Republic

Netvorice

France

Baudemont

Cergy

Decines

Germany

Langenfeld

Hungary

Budapest

Italy

Lainate

Netherlands

Breda

Poland

Warsaw

Portugal

Baltar

Russia

Moscow

U.A.E.

Dubai

U.K.

Buckingham

Asia - Pacific

Australia

Brisbane

Melbourne

Sydney

China

Beijing

Chengdu

Guangzhou

India

Delhi

Hyderabad

Pune

Korea

Seoul

Philippines

Makati City

Singapore

Factories

Brazil

Alphaville

China

TaiAn

Zhangjiagang

France

Charlieu

La Clayette

Moulins

Germany

Wilhelmshaven

India

Pune

Italy

Niella Tanaro

Portugal

Baltar

Fânzeres

Slovakia

Saris

USA

Manitowoc

Port Washington

Shady Grove

This document is non-contractual. Constant improvement and engineering progress make it necessary that we reserve the right to make specification, equipment, and price changes without notice. Illustrations shown may include optional equipment and accessories and may not include all standard equipment.